

About the Author

Douglas Mudgway came to the United States in 1962 to work at NASA's Jet Propulsion Laboratory (JPL) in Pasadena, California, following a 15-year career in the field of guided missile research and testing in Australia. At JPL, he was involved in the development and operation of the Deep Space Network from its infancy in the early 1960s until its maturity in the early 1990s. He retired from JPL in 1991.

His previous books include *Uplink-Downlink: A History of the Deep Space Network, 1957-1997* (NASA SP-2001-4227) and *Big Dish: Building America's Deep Space Connection to the Planets* (University Press of Florida: 2005).

A mathematics and physics graduate of the University of New Zealand, Mr. Mudgway writes and enjoys life in the wine country of Northern California.

About the Back Cover

This montage was assembled from planetary images taken by NASA spacecraft managed by the Jet Propulsion Laboratory in Pasadena, California. Included are (from top to bottom) images of Mercury (taken by Mariner 10); Venus (by Magellan); Earth and the Moon (by Galileo); Mars (by Mars Global Surveyor); Jupiter (by Cassini); and Saturn, Uranus, and Neptune (by Voyager). As of 2007, no spacecraft have yet visited Pluto. (PIA 03153, courtesy of NASA/JPL-Caltech)

About the Front Cover

The image used on the cover of this book was derived from this beautiful portrait of William H. Pickering, which was executed by Jet Propulsion Laboratory artist Arthur Beeman. The portrait was presented to Dr. Pickering upon his retirement by Assistant Laboratory Director Fred Felberg, on behalf of all JPL employees, at a reception in the Pasadena Conference Center on Friday, 19 March 1976. A treasured personal artifact of William Pickering's career at JPL, the original remains in the possession of the Pickering Family Trust. (Used by permission of the Pickering Family Trust.) (P16396, courtesy of NASA/JPL-Caltech)

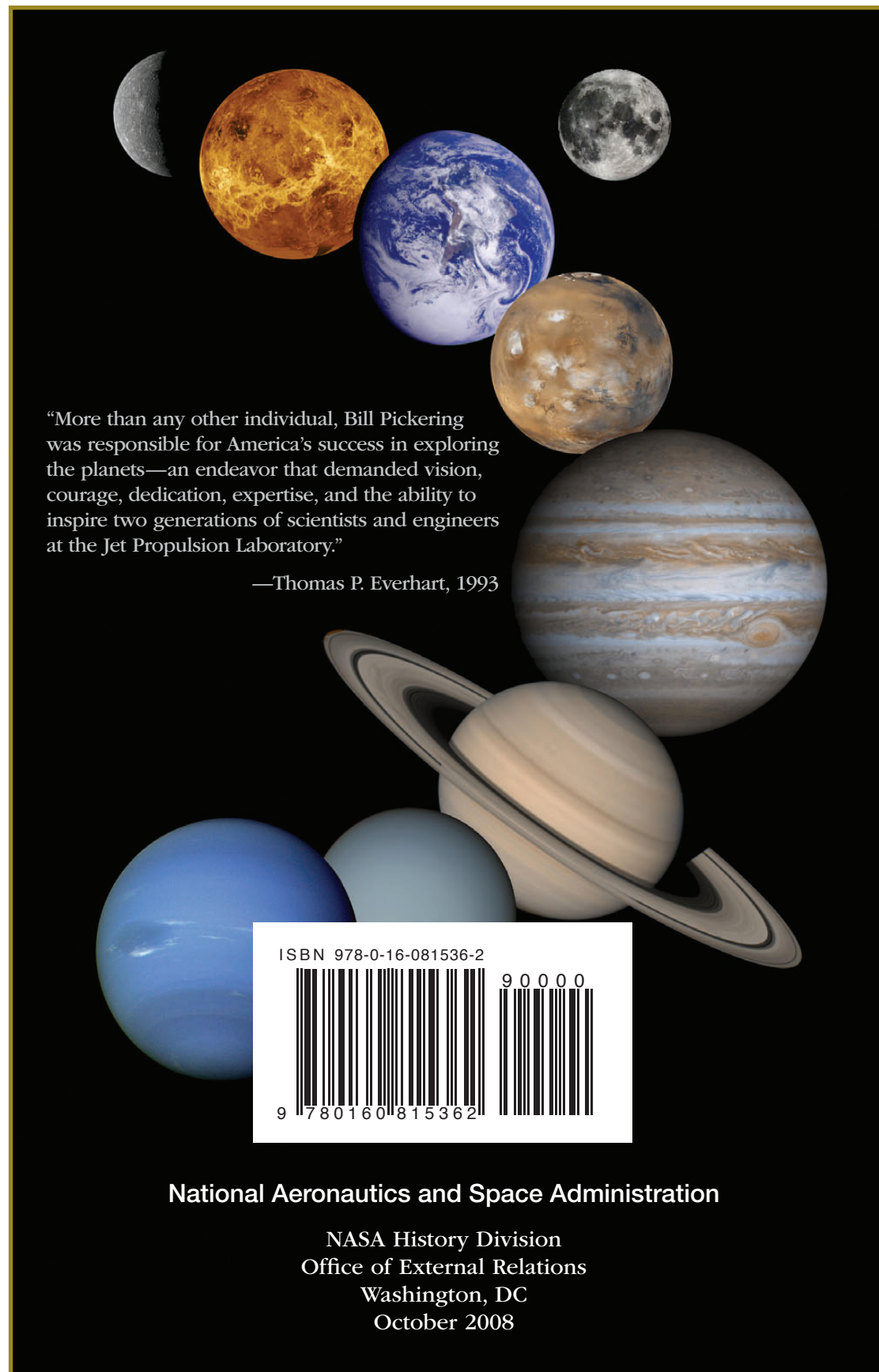
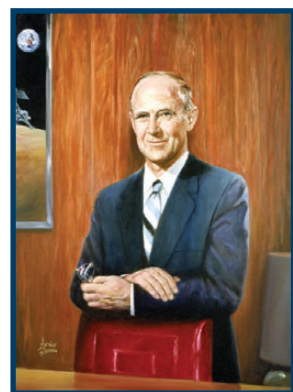

"More than any other individual, Bill Pickering was responsible for America's success in exploring the planets—an endeavor that demanded vision, courage, dedication, expertise, and the ability to inspire two generations of scientists and engineers at the Jet Propulsion Laboratory."

—Thomas P. Everhart, 1993



National Aeronautics and Space Administration

NASA History Division
Office of External Relations
Washington, DC
October 2008

William H.
Pickering
America's Deep Space Pioneer

Douglas J.
Mudgway

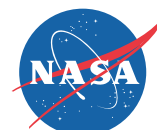

NASA
SP-2008-4113

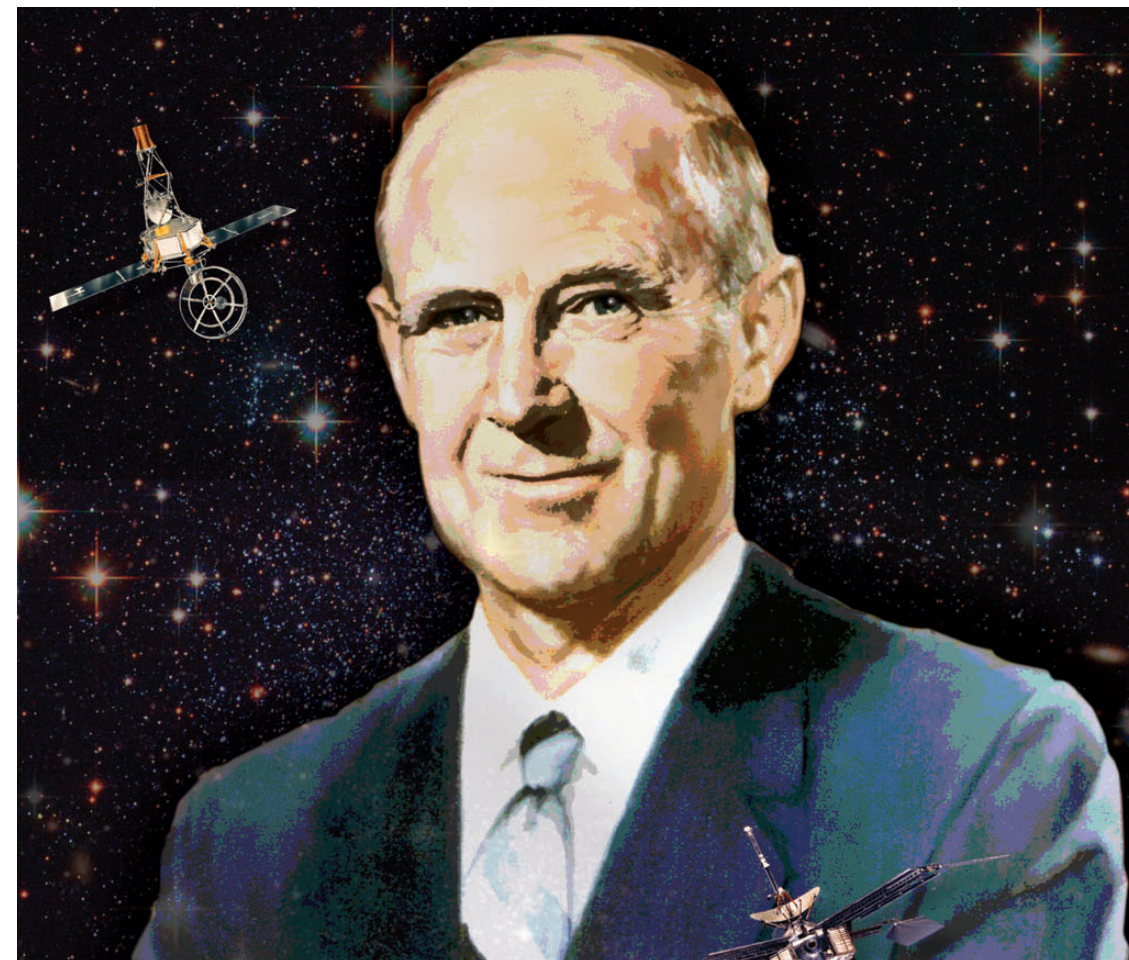

William H.
Pickering
America's Deep Space Pioneer



William H.
Pickering
America's Deep Space Pioneer

On the first day of February 1958, three men held aloft a model of Explorer 1, America's first Earth satellite, for the press photographers. That image of William Pickering, Wernher von Braun, and James Van Allen became an icon for America's response to the Sputnik challenge.

Von Braun and Van Allen were well known, but who was Pickering? From humble beginnings in a remote country town in New Zealand, Pickering came to California in 1928 and quickly established himself as an outstanding student at the then-new California Institute of Technology (Caltech).

At Caltech, Pickering worked under the famous physicist Robert Millikan on cosmic-ray experiments, at that time a relatively new field of physics. In 1944, when Caltech's Jet Propulsion Laboratory (JPL) was developing rocket propulsion systems for the U.S. Army, Pickering joined the workforce as a technical manager. He quickly established himself as an outstanding leader, and 10 years later, Caltech named him Director of JPL.

And then, suddenly, the world changed. In October 1957, the Sputnik satellite startled the world with its spectacular demonstration of Soviet supremacy in space.

Pickering led an intense JPL effort that joined with the von Braun and Van Allen teams to answer the Soviet challenge. Eighty-three days later, on 31 January 1958, America's first satellite roared into Earth orbit.

A few months after that, Pickering's decision to affiliate JPL with the newly formed National Aeronautics and Space Administration set the basis for his subsequent career and the future of NASA's ambitious program for the exploration of the solar system.

In the early days of the space program, failure followed failure as Pickering and his JPL team slowly ascended the "learning curve." Eventually, however, NASA and JPL resolve paid off. First the Moon, then Venus, and then Mars yielded their scientific mysteries to JPL spacecraft of ever-increasing sophistication.

Within its first decade, JPL-built spacecraft sent back the first close-up photographs of the lunar surface, while others journeyed far beyond the Moon to examine Venus and return the first close-up views of the surface of Mars. Later, even more complex space missions made successful soft-landings on the Moon and on Mars.

Pickering's sudden death in March 2004 at the age of 93 was widely reported in the U.S. and overseas. As one NASA official eulogized him, "His pioneering work formed the foundation upon which the current program for exploring our solar system was built."

On this, the 50th anniversary of the beginning of the Space Age, it is proper to remind ourselves of the ordinary people who met the extraordinary challenge to make it happen.



Headquarters

Washington, DC 20546-0001

October 2008

Dear Reader:

Please note that this is an updated version of the 2007 edition of *William H. Pickering: America's Deep Space Pioneer*, with typographical errors corrected. The content remains the same. Thank you very much.

Sincerely,

A handwritten signature in black ink that reads "Stephen Garber". The signature is written in a cursive, flowing style.

Stephen Garber
NASA History Division

William H.
Pickering
America's Deep Space Pioneer

ISBN 978-0-16-081536-2



For sale by the Superintendent of Documents, U.S. Government Printing Office
Internet: bookstore.gpo.gov Phone: toll free (866) 512-1800; DC area (202) 512-1800
Fax: (202) 512-2104 Mail: Stop IDCC, Washington, DC 20402-0001

ISBN 978-0-16-081536-2

William H.
Pickering
America's Deep Space Pioneer

Douglas J. Mudgway

The NASA History Series

National Aeronautics and Space Administration
NASA History Division
Office of External Relations
Washington, DC
2008
NASA SP-2008-4113

Library of Congress Cataloging-in-Publication Data

Mudgway, Douglas J., 1923-

William H. Pickering: America's deep space pioneer/by Douglas J.
Mudgway.

p. cm. — (NASA history series ; Special Publication 2008-4113)

Includes bibliographical references and index.

1. Pickering, William H. (William Hayward), b. 1910-2004.

2. Astronautics—United States—Biography. I. Title.

TL789.85.P54M84 2007

629.4092—dc22

[B]

2007019158

Please note that this is a corrected version of NASA SP-2007-4113.

“To set foot on the soil of the asteroids, to lift by hand a rock from the Moon, to observe Mars from a distance of several tens of kilometers, to land on its satellite or even on its surface, what can be more fantastic? From the moment of using rocket devices a new great era will begin in astronomy: the epoch of the more intensive study of the firmament.”

KONSTANTIN E. TSIOLKOVSKY,
Father of Russian Astronautics: 1896

“This nation has tossed its cap over the wall of space, and we have no choice but to follow it.”

JOHN F. KENNEDY,
President of United States of America:
November, 1963

Contents

Foreword	<i>ix</i>
Preface	<i>xi</i>
Acknowledgments	<i>xv</i>
1 The Boy from Havelock	1
2 The Cosmic Ray Researcher.....	21
3 The Cold War Warrior	41
4 The Space Age Begins	73
5 The Learning Curve.....	91
6 The Steep Part of the Curve	121
7 Point of Inflection.....	145
8 New Initiatives	171
9 An Active Retirement	197
10 Full Circle.....	219
11 In Retrospect.....	231
Bibliography	235
A Note on Sources.....	239
Index.....	241
NASA History Series.....	247

Foreword

The Institute of Professional Engineers New Zealand (IPENZ) Foundation is delighted to have this opportunity to make some remarks in support of this most commendable and authoritative biography of William Pickering by his colleague and friend Douglas Mudgway.

The IPENZ Foundation is a charitable trust formed by the IPENZ in 2002 for the promotion of the engineering profession in New Zealand and to assist in the welfare of its members. William Pickering, one of our most distinguished New Zealanders and an Honorary Fellow of IPENZ, was invited to become the Foundation's inaugural patron. He accepted with alacrity, met with the trustees on his many visits to New Zealand, and maintained a lively interest in the Foundation until his death. He is sadly missed.

In the course of researching the feasibility of sponsoring a biography of William Pickering, the Foundation became aware that preparation of this book was well under way under the auspices of the NASA History Division. We are pleased therefore to be able to perpetuate the memory of William Pickering in New Zealand by our association with this biography, which we see clearly as part of our mission to promote the engineering profession.

William Pickering was a modest man, but his achievements were legion, as the reader will learn from this wonderfully illustrated and very readable biography. He was a spaceflight and rocket engineer and the revered leader of the Jet Propulsion Laboratory at Pasadena in the early heady days of space exploration. The author had the inestimable advantage of knowing Bill and being able to interview him and subsequently, after his death, having full access to his papers.

Douglas Mudgway, also a New Zealander by birth, graduated from the University of New Zealand before moving to the Jet Propulsion Laboratory in 1962 following a 15-year career in Australia in the field of guided missile research.

The IPENZ Foundation is thus doubly proud to be associated with this prestigious NASA publication about a former New Zealander by a former New Zealander. We commend this book to readers in the United States, New Zealand, and around the world who remain in awe of the achievements of the early pioneers of the Space Age. Who can forget the photo (reproduced in the book) of William Pickering, James van Allen, and Wernher von Braun holding aloft the model of Explorer 1 following the successful launch of the first U.S. satellite in 1958?

John Cunningham
Chair
IPENZ Foundation
Wellington, New Zealand

Preface

William Pickering first came to the attention of the world in 1958 when the media triumphantly announced the successful launch of Explorer 1, the American response to the Soviet deployment a few months earlier of the first Earth-orbiting satellite Sputnik. Along with Wernher von Braun and James Van Allen, William Pickering shared the limelight and the accolades. In that instant of time the Space Age was born, and with it the professional reputation of William H. Pickering.

By that time, he had already been the Director of the Jet Propulsion Laboratory for more than three years, and had been associated with the Laboratory for about ten years prior to that time as the head of one of its principal engineering divisions engaged in secret guided missile tests for the U.S. Army.

Shortly after the National Aeronautics and Space Agency (NASA) was established in 1958, Pickering became responsible for carrying out NASA's Ranger program, a bold step to return live, close-up video images of the lunar surface in the last few moments before spacecraft impact. Although the program got off to a discouraging start, Pickering remained confident of ultimate success and, soon enough, the world saw its first close-up pictures of the Moon. These were followed by more sophisticated lunar missions that expanded our knowledge of the Moon and paved the way for the Apollo manned landings on the Moon.

Successful though they were Pickering saw these remarkable achievements as merely the beginning of man's venture into deep space. Under NASA's sponsorship, JPL shifted its focus outward, beyond Earth and the Moon, to the planets, beginning with Venus and Mars. Later, Pickering would push the envelope of JPL's interest even further outward, toward the very edges of the solar system itself, with missions to Jupiter, Saturn, Neptune, and Uranus.

When he retired in 1976, Mariner spacecraft had visited Mercury, Venus, and Mars, and Jupiter had been reconnoitered by each of the two Pioneer spacecraft and two massive Viking spacecraft were in orbit around Mars, each preparing to release a robot Lander to explore the surface of Mars. JPL teams were also preparing to launch two Voyager spacecraft both of which would conduct an amazing 20-year odyssey of all the major planets of the solar system that came to be known as the Grand Tour. This was the legacy that Pickering left for others to build upon, in mankind's relentless pursuit of scientific knowledge and understanding of its place in the "grand scheme of things."

In the years that followed, JPL continued to advance NASA's program of planetary exploration with great success. From time to time Pickering's name

appeared in the local newspapers and, those of us at JPL who were interested, learned that he had been invited to Saudi Arabia to setup an institute of technology for the Saudis. A few years later, we heard that he was back in the U.S. and had become involved in development of an alternative fuel for domestic home heating applications. Of the details we knew nothing.

Later, in retirement I found occasion to reflect on what kind of person William Pickering really was and how he had suddenly appeared on the national scene, just when a man like him was needed most. As part of his engineering work force at JPL, I had seen our Director only as a reserved, well-informed man of academic manner whose legendary achievements were a matter of public record, but the persona of this taciturn, tight-lipped man remained hidden from my view.

Early on a brilliant fall afternoon just before Thanksgiving 2002, I called on William Pickering to seek his concurrence and cooperation in writing the story of his professional life. With the passing years, the need to do that had become more imperative and I finally resolved to make the effort. "It might be an interesting idea to kick around," he said in response to my proposal. We chatted back and forth for the rest of the afternoon until it was, obviously, time for me to go. For the next year, in intensive oral interviews, Pickering generously recalled the personal and professional details of his remarkable life, spanning 93 years from childhood in New Zealand to his retirement years in California.

In the following pages I have embedded what he told me in the context of the major events in the American space program in which he played a significant part, significant indeed. In a 1965 article that spoke of Pickering's career at JPL to that time, a leading New York newspaper suggested that his greatest contribution may have been his positive efforts to influence government and public attitudes toward support for the space program, and his determination to rally public confidence in the nation's power to recover from the shock of Soviet dominance in space engendered by the Sputnik affair and subsequent Soviet Moon shots. More than 30 years later, Thomas Everhart, a former president of Caltech, would write, "More than any other individual, Bill Pickering was responsible for America's success in exploring the planets. . . ." These would become his legacies in the American record of space exploration and endeavor.

As in all large enterprises, the top executive gets all the credit despite the obvious fact that the ultimate result is the outcome of the integrated efforts of the thousands of individuals involved. It is also true that the top executive gets all the blame when the outcome turns unfavorable. This was never more true than during Pickering's tenure as Director of JPL. Pickering understood this and thought of himself and JPL, that is, the people of the "Lab" as he called it, as synonymous. Thus, in recalling his story of success and failure, he found it difficult to separate his individual contribution from that of the Laboratory as a whole. The media attention that focused the public spotlight on William Pickering, the

individual, tended to overlook the enormous infrastructure that produced the space spectaculars for which he received the credit—or the blame.

Nevertheless, Pickering believed there were two areas for which he was solely responsible. First, he believed that it was his job to create a work environment at the Laboratory that would attract, and retain, the very best engineering and scientific talent to work on its programs. And second, he believed that it was his job to use his public image to foster public support for the U.S. space program and its preeminent position in space exploration. In achieving these ends he engendered strong critics at NASA Headquarters, for his hubris in the former case, and his inordinate expenditure of government time and effort to public speaking and the advancement of professional societies in the latter case. Undeterred by the criticism, Pickering nevertheless forged ahead to realize the ultimate vindication of his responsibilities as he saw them.

After he became Director, William Pickering published little in the way of technical material, preferring rather to make use of his outstanding skills as a public speaker, to present his views and opinions on space and, later, the human condition, to professional and public audiences alike. I have made frequent use of his public speeches to afford a window on his inner thoughts on these topics as they caught his interest over the 20-year period of his involvement with the space program. The archives of both the JPL and Caltech contain much additional material about Pickering and his tenure as Director that remains to be mined by future researchers.

In a life spanning most of the 20th century, William Hayward Pickering rose from the most humble beginnings to achieve worldwide recognition by the highest institutions in the field of science and technology. The institutional story of JPL during Pickering's tenure has been well told elsewhere.¹ This is the personal story of William H. Pickering the man, before, during, and after that climactic period of his life.

Sonoma, California

October 2007

¹ Koppes, Clayton R. *JPL and the American Space Program: A History of the Jet Propulsion Laboratory*. New Haven: Yale University Press, 1982.

Acknowledgments

In the task of researching and writing this book, I count myself very fortunate to have enjoyed the personal confidence, support, and encouragement of William H. Pickering for the final three years of his life. After he suddenly passed away in March 2004, I was equally fortunate to have received a continuation of that confidence and support from his daughter, Beth Pickering Mezitt, and his wife, Inez Chapman Pickering. To both of these ladies I am deeply indebted for their gracious help with details of William Pickering's personal life, and for their generous access to the collected personal papers and photographs of William Pickering.

I am also indebted to R. Wayne Mezitt, Trustee for the Pickering Family Trust, for permission to publish the manuscript.

The Archives and Records Section of JPL assisted me with my research in its William H. Pickering Collection and the Millikan Library at Caltech provided me a copy of his thesis and copies of various technical papers dealing with Pickering's early work on cosmic rays at Caltech. The Alexander Turnbull Library in New Zealand generously provided me with background photographs and material related to Wellington in the 1920s to supplement the material on Pickering's years at Wellington College that came from the College Archives Director, Paddianne Neely. The staff at the Marlborough Provincial Museum and Archives in Blenheim, New Zealand, supported this project with background material relating to Havelock for almost 30 years that included young William Pickering's childhood.

A special note of thanks is due to indefatigable Dr. John Campbell of Canterbury University for his concept of the Rutherford-Pickering Memorial in Havelock and his untiring effort to bring the concept to reality. His splendid book on Rutherford provided much insight into life in early Havelock. Also in New Zealand, Alan Hayward and Carol Short, members of the Hayward and Pickering families, respectively, provided recollections and memorabilia for which I am truly grateful.

In reconstructing Pickering's professional career I have drawn upon previously published material from "JPL and the American Space Program," by Clayton R. Koppes; "Exploring the Unknown," by John M. Logsdon; "Beyond the Atmosphere," by Homer Newell; "Rutherford," by John Campbell; "Haywood Heritage," by Stuart Bunn; "Millikan's School," by Judith R. Goodstein; "The Rise of Robert Millikan," by Robert H. Kargon; "The Universal Man," by Michael H. Gorn; and various articles on William H. Pickering from *Time* magazine, *The New York Times*, the *Los Angeles Times*, the *Pasadena Star-News*, Marlborough Express, *The Press Christchurch*, the *Evening Post*, the *Dominion*, and the *Auckland Herald*. I am indebted to the authors and publishers of these various works.

Dr. Steven Dick, NASA Chief Historian, and Erik Conway, JPL Historian, provided insightful comments on my representation of NASA, Caltech, and JPL during Pickering's time for which I am profoundly grateful. Stephen Garber and the staff of the NASA History Division provided invaluable editorial guidance.

In the Communications Support Services Center at NASA Headquarters, Ann-Marie Wildman expertly designed the layout of the book and Steve Bradley adapted the cover art and designed the dust jacket. Stacie Dapoz oversaw the careful copyediting and proofread the layout, David Dixon handled the printing, and Gail Carter-Kane and Cindy Miller supervised the whole production process. These talented professionals gave form and finish to the manuscript, an onerous task that earns my admiration and appreciation..

Finally, I had the unique experience of working as a high-level engineer at JPL during the last 15 years of William Pickering's tenure as Director. His influence on all that happened there in those years percolated down to me, thereby inspiring me and my colleagues alike to do greater things, to reach further, to do better than we or others had done before, to always understand fully what we were doing and why we were doing it, and, above all, to pursue excellence in all that we did. For that experience too, I am grateful.

Chapter 1



The Boy from Havelock

The Monument (2003)

The little town proclaimed its position in the general order of things by two large billboards that were prominently located on the main road at either end of the business area that consisted of several stores, a few cafés, a post office, and two pubs. Against a postcard-like background of green hills, shining water and blue sky, the billboards shouted their greeting: “Welcome to Havelock: Greenshell Mussel Capital of the World.” It immediately captured the attention of the tourists and it was good for the town’s main business—greenshell mussel farming.



Welcome to Havelock: Greenshell Capital of the World (Photo: S. Mudgway).

However, there was much more to Havelock than these two billboards suggested. In the center of the town, adjacent to the Town Hall stood a tall stone monument known as the “Ronga.” Over the years, time and weather had all but obliterated the inscription, and most of the passers-by took little notice of it. The monument commemorated the loss of the schooner “Ronga” in April 1906, in which six local townsfolk lost their lives.¹

There it stood for almost 100 years as the memories faded and those who remembered passed away. Eventually it became simply an artifact of Havelock, a rather dilapidated symbol of public enthusiasm for a long since forgotten cause.

However, as the new century began, an ambitious initiative began to stir in the town councils of Havelock. It was driven by John Campbell, a professor of physics from the University of Canterbury. In his recent book on the life of Lord Ernest Rutherford,² Campbell described Rutherford as “. . . one of the most illustrious scientists the world has ever seen. He is to the atom what Darwin was to evolution, Newton to mechanics, Faraday to electricity, and Einstein to relativity.”³ Although Rutherford was born in nearby Nelson, he received his primary education at the tiny country school of Havelock.

In John Campbell's mind, the New Zealand public paid insufficient homage to its world-famous son, and he was determined to do something about it. For a decade, he worked to promote public appreciation of Rutherford by giving talks and lectures in schools and conferences, promoting exhibitions and displays in public places, and distributing information to schools. By 1991, he had been instrumental in implementing the “Rutherford Birthplace Project” a memorial plaza in the adjacent city of Nelson, where Rutherford went to secondary school, or “college,” as it is called in New Zealand.

However, the splendid Rutherford Plaza, being in Nelson, left the town of Havelock without any formal recognition of its association with the great man. Campbell could not resist a challenge to do something about that, too.

At that point, Campbell recalled meeting another famous New Zealand scientist during his visit to the University at Christchurch in the early 1980s. In the course of their conversations, Campbell learned that, by an extraordinary coincidence, this famous scientist had also lived in Havelock and been educated in the same little primary school at Havelock, just a few years after Rutherford. Like Rutherford before him, he had to move elsewhere to complete “college” and university education before going on to attain world fame in another country. His name was William Pickering and he went on to become the pioneer of America's space exploration program.

This was the compelling reason Campbell needed. He would give Havelock a memorial to not one famous son, but two: Earnest Rutherford and William Pickering—both giants in stature on the world scene of science and technology. Campbell persuaded local government officials that a memorial plaza to recognize Havelock's association with these two famous scientists would

enhance the status of the township. It would not degrade its natural beauty and, he said, “It would probably increase Havelock’s tourist trade.” The “Ronga” monument would be a perfect site for the new memorial. With this agreement in hand, Campbell initiated the project.

On 15 March 2003, in the presence of representatives of the principal patrons, civic officials, dignitaries from the local Maori tribe, Ngati Kuia,⁴ an assembly of school children, some 200 guests and many curious tourists, William Pickering, the surviving honoree, unveiled the Rutherford-Pickering Memorial. It stood adjacent to the “Ronga” monument, near the town hall on the main road.

For New Zealanders, their connection with an international figure of the stature of William Pickering was cause for considerable national pride. His achievements were legendary. In 1958, he had led America’s successful challenge to the Soviets’ bid for technological supremacy.⁵ His image had appeared on the cover of *Time* magazine on two occasions, first in 1962 for the world’s first robotic spacecraft visit to Venus, and again in 1964 for an encore expedition to Mars. These missions were not of course, individual ventures, they were part of the United States’ space program, which was managed and executed by the National Aeronautics and Space Administration (NASA). They were led, however, by individuals that possessed the unique technological experience and who had innovative minds, driving motivation, and confidence to go where none had gone before, and whose reputation and personality



The Rutherford-Pickering Memorial Plaza, Havelock, March, 2003. The “Ronga” monument stands to the center rear of the photo. The historic town hall is to the left-Mussel Boys Café is further down the street to the right (Photo: D. Mudgway).

inspired others to follow. Those were necessary, but not sufficient conditions for success. Being in the “right place at the right time” was the culminating and sufficient condition. Such a man was William Hayward Pickering, a quiet boy from Havelock who rose to become a distinguished public figure, showered with international honors for his contributions to the advancement of human knowledge in the esoteric world of scientific space exploration. Here was where it all began.

Havelock (1913)

William Pickering (senior) came from a sturdy line of English immigrants who had settled originally in Australia in the mid-1800s before immigrating to New Zealand in 1860. He established a coaching business in 1879 and for many years thereafter, William Pickering's coach was a familiar sight and service to travelers on the roads between Havelock and Blenheim.

In 1880 at age 34, William Pickering, Coach Proprietor, by then a successful and well-liked citizen of Havelock, met and married the beautiful Miss Kate Douslin; she was the daughter of William Douslin, a prominent member of the Blenheim Borough Council.



Mr. W. Pickering's Coach: First to make the journey from Blenheim to Nelson in 1885 (Photo: Carol Short).

As the years passed, William and Kate were prosperous. They would never become wealthy, but they were solid pioneering citizens struggling to make a life under the harsh conditions common in the remote areas of early New Zealand. Although both William and Kate were folk of little education, they appreciated the value of learning. All six children were enrolled in succession at the Havelock Primary School. At any one time in the mid-1880s, there was a Pickering child in every class from the Lower School to the Upper School. "Pickering" became a most common name in and around the Havelock area. Education was encouraged in the Pickering household and all of the children did well at their school-work, but their first-born, a son named Albert, did particularly well.

By the time Albert Pickering reached the age of six and was ready to start school, an older boy named Earnest Rutherford had already been at the upper classes of the school for two years and was about to enter the examinations required to continue his education at one of several prestigious secondary schools or "colleges."

Albert Pickering followed a similar path through the higher educational system of the times, eventually earning a diploma in Pharmacology. He embarked on a professional career as a qualified pharmacist, and married Elizabeth Ann Hayward, an attractive businesswoman from the Dunedin area of New Zealand in 1908.⁶

Shortly thereafter, the newlywed couple moved to the capital city of Wellington, where Albert "Bert" took up his business profession in the city, while Elizabeth Ann "Bess" set up a home and prepared for the birth of their first child. William Hayward Pickering arrived on Christmas Eve 1910, and was regarded by both adoring parents as the ultimate Christmas present. Their joy and happiness was shared by both sets of grandparents and their large families of brothers and sisters in Havelock and Dunedin.

A second child, a son they named Balfour, was born in 1913 and their family seemed complete. By then, Bert had entered service with the New Zealand government as a pharmacist in the Office of Public Health. Their prospects were bright and future seemed secure. Then tragedy struck.

Shortly after the birth of Balfour, Bess contracted peritonitis, and died in June 1915 after a protracted period of severe illness. She was 38 years old. For a while, Bert struggled to hold the home together while he tried to reshape his life after the loss of Bess. That, however, was not to be.

A few months later, baby Balfour contracted diphtheria and despite Bert's professional expertise, the drugs available then could not save the child's life.

To exacerbate the problems facing Bert Pickering, the Office of Public Health assigned Bert to an overseas position as Public Health Officer at Apia, Western Samoa, an area controlled by Germany prior to World War I; now occupied by New Zealand troops. Realizing that it was impossible to take young Will with him under the circumstances, Bert made an agonizing deci-

sion to part with the sole remaining member of his family. He transferred the care of young Will to his grandparents in Havelock, then moved from Wellington to take up the government position in Samoa.

The home of William and Kate Pickering, humble though it was, provided a loving and accepting environment for a young child and, after a short period of anguish at the separation from his father, Will settled down and soon adapted to the new world that surrounded him.

From time to time, Will's father returned to New Zealand on furlough from Samoa. On one such occasion in December 1916, Bert brought presents for his son's 6th birthday and enjoyed a Havelock Christmas with his family. The new year came and passed rather somberly as New Zealand marked the third year of its engagement in World War I while Bert stayed on in Havelock partly to be with his son, but more particularly to start Will at school. It seemed important to Bert that he should see Will off to this important new phase of his young life.

In the New Zealand education system of the time, children began their primary school education at age 6 and remained in that system until age 12 or 13, after which they could, if they qualified by examination, continue with their education at the secondary school level. The Havelock Primary School was part of this system.⁷

Will Pickering soon made an impression at Havelock Primary School. Well-behaved, quick to learn, interested in everything, and equipped with a naturally retentive memory, Will quickly grasped the basics of reading, writing, and arithmetic. Always a great explainer, Will soon began to recreate school at home, where he would play the role of teacher while his amused grandparents played his classmates.

Two years after he began, Will Pickering passed out of the Lower School into the tutelage of a Mr. Barraclough, in the Upper School. At age eight, he regarded himself as a big boy, and with his customary quiet confidence began the new school year of 1919 at the class level of Standard 2. It was not long before Mr. Barraclough too, began to notice the presence of an outstanding pupil among his new class, and began to take a particular interest in his progress. Will became known as the "smart" boy of the school.

Year after year, Will moved steadily through the ever-advancing class levels, demonstrating superior skills in all subjects but excelling particularly in science and arithmetic. Will's scholastic ability was such that he was able to combine two of the standard levels into a single year, and to expand the breadth of his studies to include algebra and Latin in addition to the regular curriculum of English, composition, history, geography, and science. He excelled at all of them.

Although Bert seldom saw his rapidly growing son, he was able visit Havelock on several occasions when on leave from his government post in Samoa. He

would have been astonished each time to see the increase in Will's stature, self-confidence, and general knowledge. They went on outings together, and on more than one occasion visited the Hayward family in Dunedin.

As Will's reading and writing skills rapidly matured, Bert was able to keep in touch by exchanging letters with Will, and to reassert his presence in the child's life. Will's letters described the more significant things that were happening in his young life.⁸

From time to time during the school holidays, his mother's family, the Haywards, invited Will to stay at their large family home in Dunedin. Those times were filled with great fun and affection, and Will fit into the large family environment. The younger son, Jock, was about his own age and the two boys enjoyed each other's company, and eventually became life-long friends.

At that time, Havelock, like most other small towns in New Zealand, did not have electricity. However, a simple electric generator driven by water from a small dam nearby provided current for about two hours each evening for those few citizens affluent enough to have installed electric light. This literally "sparked" the interest of young Will in a way that would become evident in the years ahead.

Will Pickering turned 11 years old in December 1921, and looked forward to entering the final class, Standard 6, at Havelock when school resumed in February 1922 after the long Christmas vacation. His confidence was made evident by his class marks; he was an outstanding pupil and had always been at the top of his classes.

In the New Zealand educational system at that time, a Certificate of Proficiency was required both as evidence of a completed primary education,

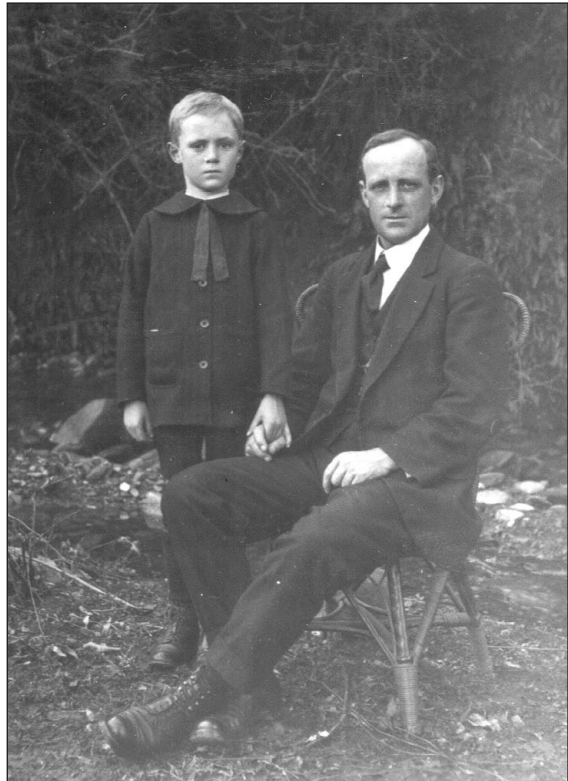

Albert William Pickering "Bert" with son, William Hayward Pickering "Will," circa 1919 (Photo: NASA/JPL-Caltech Archives P2395B).



Will Pickering strikes a wild game hunter's pose at the Hayward's holiday cottage near Dunedin, circa 1921 (Photo: NASA/JPL-Caltech Archives P2396A).

and as a necessary qualification for continuation to a secondary education in either a high school or a college. It was an essential key to the future education of all children throughout the country. The dreaded proficiency examination was administered at the end of the year in which the pupil reached the Standard 6 level, and carried with it a certain aura of apprehension among children and parents alike. The Pickering family, however, had no concerns about Will's ability to pass the proficiency exam, and never doubted that he would go on to college and do well. They simply assumed that

he would succeed. And of course he did, with top grades.

When the proficiency test results came out early in the new year, Will's name topped the list of those who passed. He received a Certificate of Proficiency to mark his success, and a short time later, his father arrived back from Samoa to take him to college⁹ in Wellington.

Will Pickering would not have known it at the time, but he was about to step into an environment that was the very antithesis of the gentle, loving, and caring atmosphere that had surrounded him in Havelock, but one which would lead him in due course to his destiny on the other side of the world. Will Pickering was, as they would say in New Zealand, "going to college."

Wellington (1923)

In February 1923, when Bert Pickering enrolled his 12-year-old son at prestigious Wellington College, the college had stood on its present site for almost 50 years. For a new country like New Zealand, the college had already established a long and distinguished history.¹⁰

The school was steeped in tradition, and prowess in the fields of art, scholarship, government service, military service, and sport: cricket and rugby were most highly regarded and memorialized in the school's list of honorees and honors boards. Those who succeeded in these areas were held up as heroes, and lauded as examples of selfless dedication and loyalty to school, country, and Empire. In short, the school exemplified the spirit of the time. It was a

strong reflection of New Zealand’s British origin and its close ties to England and the British Crown. Discipline was strict, corporal punishment was accepted, military training was part of the regular curriculum, and scholastic standards—measured by frequent, unforgiving testing—were high.

Wellington College adhered strictly to the common English public school practice of a uniform dress code. All pupils, regardless of age, were required to wear the school uniform at all times during school hours and during travel to and from school. There were penalties for infringement of the dress code rules. The official uniform, which was quite an expensive item for those times comprised short, gray, knee-length pants, a gray tailored jacket, gray woolen shirt and tie, knee-length pull-up black socks with two gold bands—which were the school colors—around the tops, black dress shoes, and black peaked cap with radial gold stripes. At the front, embroidered in gold thread, the cap bore a medallion proclaiming the school icon, an oil-lamp surmounted by a banner bearing the school motto in Latin, *Lumen Accipe Et Imperti*: “Receive the Light and Pass it On.”



Pupils of Wellington College, circa 1923. In front row are Lord Jellicoe (center) and Headmaster J. P. Firth (left). The school buildings are in the background (Photo: Alexander Turnbull Library, Wellington, New Zealand, Image No. 005413).

Also in keeping with English public school practice, the school year was divided into three terms, with a long break of six weeks following the third term that corresponded to summer; Christmas and New Year in the Southern Hemisphere. The first term began in February and the third term ended in December.

When the first term of the college school year began in late summer 1923, the school roll numbered about 800, of which about 60 were boarders. Will Pickering was among the annual intake of new boys, and he was a boarder, enrolled on the "general" side. Henceforth he was known formally as Pickering, W. H., or just plain "Pickering" among his masters and peers. To the other boarders he was "the boy from Havelock."

Although Pickering's father remained in Samoa the entire time he was at college, his son seemed to be quite happy with the arrangement, and satisfied to divide his vacation time between Havelock, Dunedin, and his Uncle Horace Douslin, at Rotorua.¹¹ As "Willie," he was an excellent correspondent, and wrote regularly to both his father and his grandmother describing the events of his new life at college.¹²

For a boy who had just turned 12 years old, Pickering was rather tall, of slight build, and was healthy and strong. He was shy, with fair hair, and a quiet and thoughtful disposition. Although he was friendly enough to those with whom he came in contact, he was not particularly gregarious, and seems to have made few close friendships during his college years. But he was adaptable, self-confident and smart, as events soon showed.

Pickering quickly adapted to the school and boarding house routines without suffering psychological stress due to separation from his Havelock home and family. Undoubtedly, his innate academic ability eased the burden of a full load of class work: English, French, Latin, mathematics, science, history, and geography. His regular exam results were consistently at the top of his class and in the masters' "common room," the "boy from Havelock" had begun to attract attention as a quiet achiever who would ultimately¹³ do well.

In addition to keeping up with his class work, Pickering involved himself in several non-academic activities in that first year.

He had learned how to shoot a .22 gauge rifle during his past holidays with the Haywards in Dunedin and brief as it was, this prior experience quickly led him to a place on the college shooting team. He joined the debating society and wrote: "Last Thursday we had a debate on the subject of coeducation in secondary schools. It was defeated"; played football: "I have been playing football this term, also taking dancing [lessons]"; and achieved some success in athletics: "I won by about a yard or so in 5 minutes, 22 seconds."¹⁴

However, his interest in another activity, the radio club, was to have far-reaching significance for him in ways that he could not possibly have imagined. The first glimmer of interest appeared in his mid-April letter to his father, "On the 1st, there was a meeting of the radio club. The class instruction on the theory of wireless commences next Thursday."¹⁵

In 1923 when Pickering started college, the “wireless” was just beginning to make its public appearance in New Zealand as a new entertainment medium. Already, amateur radio enthusiasts had established an active, worldwide organization and, by 1923, there were a substantial number of amateur radio stations operated by “hams” scattered throughout New Zealand. They exchanged messages between other amateurs in Australia, the U.S., and other countries around the world, as their limited equipment would permit.

Wellington College was the first public school in New Zealand to have its own amateur radio station and it was the radio club that initially attracted Pickering’s interest. In Pickering’s first year, the club had built wireless receiving equipment which was used to detect and log amateur broadcasts from all over New Zealand and, occasionally, from Australia and the U.S. depending on conditions. He asked his father to buy him a wireless valve (radio tube)—a very exotic device at that time—to build an improved wireless receiver, “I think the best kind of valve will be a V201A. I have a single valve set working here and I need a transformer and another valve to make a two-valve set out of it. This should be able to get America and perhaps, England.” However, the club did not have transmitting equipment, nor did it have a license to operate a transmitter. That would come later.

By the time the 1924 school year began, Pickering, W. H. was, in many respects, a different boy. Now aged 13, he had grown a full 3 inches and had gained 14 pounds in weight. No longer a “new boy,” he had moved into the A class of the fourth-form level. Quite secure in the college environment, he excelled at his class work and again engaged in many of the extra-curricular activities that were available to him.

The school curriculum included compulsory military training, and on Friday afternoons, the entire school turned out for a formal parade followed by officers’ inspection, marching, and rifle drill.

He signed up for boxing classes, “My boxing has been alright. I have not been hurt much, yet.”¹⁷ However, it was the activities of the radio club that continued to attract his greatest attention. The year 1924 had been an important one for amateur radio at Wellington College. The club already had a wireless receiver, but that year the club members constructed a wireless transmitter, and several members acquired the necessary license to operate it on the international amateur radio bands. Pickering was caught up in the excitement of building the transmitter, putting radio Z-2BL on the air and using it effectively to contact other amateur stations throughout New Zealand and Australia. This early practical experience with radio propagation and electrical circuits was to have a seminal influence on the course of his career in later life.

His father’s ideas for his son’s future career reflected these emerging interests. William wrote his grandmother: “Yesterday I had a letter from Dad. He says that he thinks that a position in the Pacific Cable Company would be a good one for me. I think so too.”¹⁸



Cadet Pickering W.H., Wellington College Cadet Corps: 1924 (Photo: NASA/JPL-Caltech Archives Laboratory 75-4).

Another school organization that caught Pickering's attention—the Natural Science Society—was run by a member of the school staff, Mr. Stevens, who gave regular talks on topics that fell marginally within that category. Topics such as “optical illusions,” “fishing,” “chemical magic,” “electro motors,” and “the lighter side of physics” were typical. However, the *Wellingtonian*, the college year-book,¹⁹ reported that the best lecture for that year was the one on “explosives.” It was a standing-room only audience and later many of the pupils “indulged their love of noise with a good deal more enthusiasm than discretion.” Pickering thought so too, “I went to a lecture on explosives . . . that went off on their own. A good mixture was made of sulphuric [*sic*]

acid, nitric acid, and turpentine. On Saturday I bought the things but they would not work. I found out what was the matter and I will fix it and try again on Saturday” he told his father.²⁰ Young Pickering soon learned how to make percussion detonators that could be exploded by stamping on them, or striking them with a hammer much to the delight of his young friends.

In 1925, Pickering advanced to the fifth form in a special class for gifted pupils. Chemistry, mathematics, English, and Latin were the principal subjects, taught at an advanced level in order to prepare the boys for two major scholastic challenges, the Matriculation, and the Senior National Scholarship. “At the end of the year, I am entering for the Senior National Scholarship. This gives me £45 a year for two years. At present I am getting £40 a year for three years” he reported to his father.²¹ Both were key requirements for their academic future, and both were perceived by the school as a measure of its academic standing in New Zealand's educational system.

When the radio club was reorganized in 1925, Pickering was elected to the committee and began to influence the club's activities. He obtained his Amateur Radio Operator certificate, and set about improving the transmitter, receiver, and antenna. The station immediately began making contact with stations in the U.S. and an increasing number of Australian stations.²²

Pickering turned 15 in December of 1925 and spent the 6-week summer holidays with his Uncle Horace Douslin²³ on the dairy farm near Lake Rotorua in the center of the North Island. Horace Douslin was the brother of Kate Pickering, and was technically Bert's uncle. However, within the family, Will Pickering always knew him as Uncle Horace. Now retired from a professional career in Rhodesia, Horace was unmarried and comfortably well off, and had purchased the undeveloped property at Rotorua a few years earlier. Through occasional meetings in Havelock, he had formed quite an attachment to this bright Pickering lad. For his part, William Pickering was a welcome and helpful addition to the daily routine of farming life in rural New Zealand.

The Matriculation Certificate from the previous year had marked the end of Pickering's general secondary education. Now in the lower sixth form, his academic courses, English, mathematics, and science, began to prepare him for continuing on to a tertiary education at the university.

His remarkable aptitude for science and mathematics had already brought him to the attention of a senior member of the school staff by the name of A. C. Gifford. During his long association with the school, Gifford had established a small astronomical observatory equipped with a fine, 5-inch, refractor telescope on the school grounds. Being a first-class graduate from the University of Cambridge, England, and a Fellow of the Royal Astronomical Society of England, Gifford was well qualified in the science of astronomy. With his gentle disposition and fatherly manner, he attracted boys like Pickering and encouraged them to learn how to use the telescope for making astronomical observations. Gifford's instrument gave Pickering his first views of the Moon, Venus, Mars, and Jupiter. He was spellbound at what he saw. The Gifford Observatory became an additional source of absorbing interest for him in those years at college, and established within him an abiding interest to learn more about our solar system.

Pickering began his final year at Wellington College in February 1927. At 16 years of age, he had acquired an enviable school record. Supported by a network of loving people who cared greatly about him, Pickering thrived on the challenges that school life brought to him. Although the complexity of his schoolwork now approached first year university level, he appeared able to cope with the extra demands it made upon him without undue strain, and the final year passed quickly.

Under Pickering's leadership, the radio club converted a 3-valve Browning-Drake receiver to a 5-valve set, and dazzled the school assembly with a high tech demonstration of "radio reception on a loudspeaker using an indoor aerial," a major technological advance for the time.

He sustained his deep interest in the Observatory and, with Gifford's encouragement, used it to broaden his knowledge and become familiar with the motions of the Moon and planets, along with their surface features and general characteristics. But he was not satisfied. A fine instrument though it was, he could never see enough through the Gifford telescope, and always wished he could see more. If only he could get closer—but that was just wishful thinking, or so he thought.

WELLINGTON COLLEGE RADIO CLUB

Radio 02 260 WELLINGTON, N. Z.

Ur cr Sigs whd Hr 18/9/27 At 6:30 N.Z.M.T.. R 6

QRM — QRN — QSB DC QSS —

TRANSMITTER RECEIVER

Power 5 watts W.L. 89 m. Schnell

Plate V 500 Ant. 50' cage 50' hi tuner. Detros

Ant. Current .2 C.P. 5 wire fan 2 audio

Circuit bone coupled hartley

Remarks: Vg. frd. 100 om. cr. sigs. ft. for news

Pse QSL 73's. C. U. Agn

PX 02 0A0HNU WHP Pickering Opr.

PRINTED IN U.S.A.

QSL Card (Acknowledgement of radio contact) dated 18 September 1927 from Z-2BL from Wellington College radio club signed by W. H. Pickering, Operator (Photo: Wellington College Archives).

As a member of the Upper Sixth Form, the top class in the school, and an outstanding pupil in addition, Pickering was then regarded as person of distinction among the general student body.

In June of his final year at college, Pickering received a letter from Horace Douslin that was to set his course for the future. Pickering passed it on to his father: "Enclosed, is a letter from Uncle Horace and one from Grandma. You see what he is offering me. So far as I can see, it ought to be a very good thing. . . . Perhaps it would be better to get [my] B.E. here, and then go on [to America]," he wrote. He sought some advice at the college: "The other day I saw Mr. L. He seems all in favor of my going to America, but says we can't do much until we find out which university it is. He says there is a good one in Pasadena about fifteen miles from Glendale."²⁴

Soon enough they would come to find out that Horace Douslin had been speaking of the California Institute of Technology.

Undistracted by the uncertainty associated with a future university career in America, William Pickering pressed on with his school activities for the final year in Wellington. However, the American idea eventually fell through and, he felt that his immediate goal should be to complete an engineering degree at Canterbury College in Christchurch, and so to that end he set his sights.

By the end of the year, he had added a University National Scholarship to his personal list of secondary school achievements and in late December at the age of 17, left Firth House for the last time and returned to Havelock for a short summer holiday.

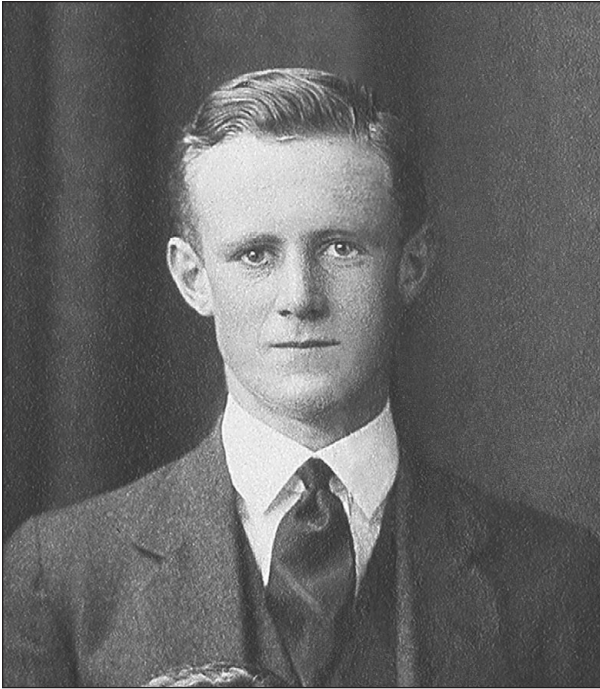

Wellington College Prefect, 1927
(Photo: Wellington College Archives).

The little town was different now; electricity had arrived and most of the houses, including the Pickering's, now had electric light whenever they needed it. Grandmother Kate never ceased to marvel at the wonder of her electric light switch. The single main street was lighted and the road through the town had been paved. Automobiles had arrived in Havelock and, although a few horse-

drawn vehicles were still a common sight in the town, the motorcar was rapidly replacing them. Petrol arrived in large cans, two to a box. There was a regular moving picture show every Saturday night in the town hall. The “talkies” had not yet come to Havelock, but they never missed what they never had, and all were content.

It was, in a sense, the end of his age of innocence and the end of his boyhood. He had stepped out alone, looked at what the world outside Havelock had to offer, and decided for himself what he wanted to do next. For him, the learning process had only just begun, and university—the road to higher learning and discovery—beckoned him.

Later that summer he moved to the large, South Island city of Christchurch, with the intention of enrolling at Canterbury University College, the engineering school of the University of New Zealand.

Christchurch (1927)

The city of Christchurch took its name from Christ Church College, Oxford, England, some of whose members, led by the Archbishop of Canterbury, formed the Canterbury Association in 1849. They intended to establish a middle-class Anglican community in New Zealand where the moral values of Victorian

England were to be upheld and preserved for future generations. When it was established in 1873, Canterbury College, as it was then known, was the second of the two colleges²⁵ that then comprised the University of New Zealand.

In the 1890s Canterbury University College enrolled a young student named Ernest Rutherford in a science course and in so doing, initiated what came to be a most remarkable scientific career. Rutherford had begun his education in Havelock and continued on to Nelson College, but it was here at Canterbury that his outstanding scientific ability took flight during a year of post-graduate research which led to a scholarship to Cambridge, England. Later, in the elite scientific community of Europe, he rapidly won a place of the highest esteem. He was a primary participant in the birth of atomic physics. The media lauded him as the scientist who first split the atom. He became one of the most illustrious scientists the world had ever known.²⁶ He was, in short, the “father of atomic physics” and New Zealand claimed him as its most famous scientist.

Thirty years later, another brilliant young student with roots in Havelock embarked at this same place for a journey that, although quite different from anything Rutherford could have imagined, would eventually place him alongside Rutherford on the dais of public recognition as one of New Zealand's most distinguished scientists. This man was William Pickering.

Canterbury College student number 431, Pickering, William Hayward, age 17, entered a course leading to the bachelor of engineering (B.E.) degree at the start of the school year 1928. His course work included pure mathematics, applied mathematics, chemistry, physics, and calculus. The lecture schedule for 1928 shows that first-year candidates for the B.E. degree were required to take 17 lectures, and not less than 12 hours of laboratory work per week. The school week included Saturdays.²⁷

It was a heavy academic load that left little or no time for extra-curricular or leisure activities. But Pickering benefited from the additional sixth-form classes that he had taken at Wellington College where much of the material with which he was now confronted had been covered.

Pickering was evidently a dedicated and capable student. He ended his first year not only with high grades in all his subjects, but also with prizes for both pure and applied mathematics. Although he had not been able to devote any attention to his favorite hobby, amateur radio, he must have counted 1928 as a very successful year. But there was more to come—more than he could possibly have foreseen.

In the two years that had passed since Pickering spent his last summer holidays on Douslin's dairy farm at Lake Rotorua, Uncle Horace had been abroad. While touring California, he met, and subsequently married, a woman from Glendale, a suburb of Los Angeles quite near the upscale cultural city of Pasadena. Douslin then established a second home for himself and his new wife in Glendale. By the time Pickering had finished his first year at Canterbury, Horace Douslin

had returned to New Zealand to attend to his farming interests, and was planning to return to his home in Glendale, California, early the following year.

At some point, Horace and Bert had occasion to discuss William's future and revisit the earlier suggestion regarding an American university. In the outcome, Horace proposed that the young man should return to California with him and complete his engineering degree there, returning later, to find a job as an electrical power engineer in New Zealand's growing hydro-electric, power generation, and distribution industry. It would let the young man see some of the world, and Horace would enjoy his company and cover the costs. He might have casually observed: "There is a new university devoted particularly to electric power engineering and science close by in Pasadena. It is called the California Institute of Technology."

A few weeks later, the steamship *Makura* pulled away from the busy port of Wellington bound for California via Rarotonga and Tahiti, listing among its passengers a Mr. and Mrs. Horace Douslin, and a Mr. William Pickering. The party occupied two first-class cabins on the port side and they were scheduled to disembark in San Francisco. Mr. Douslin was identified as "businessman" and Mr. Pickering as "student." The emigration status of the Douslin couple was that of "returning nationals" and William Pickering was listed as "immigrant."

Endnotes

- 1 Marlborough Provincial Museum and Archives, Brayshaw Museum Park, Blenheim, New Zealand, March 2003.
- 2 Campbell, John. *Rutherford: Scientist Supreme* (Christchurch, New Zealand: AAS Publication, 1999).
- 3 Ibid.
- 4 Official party from the neighboring Maori organizations.
- 5 Sputnik, the world's first Earth-orbiting satellite was launched by the Soviets in October 1957.
- 6 Bunn, Stuart. *Hayward Heritage: The Story of a Pioneer Family* (Mosgiel, New Zealand: Stuart Bunn, 1996).
- 7 Congdon, Eldred. *A Century of Education in Havelock* (Blenheim, New Zealand: Marlborough Historical Society, 1961).
- 8 Pickering, W. H. Letter to Mr. I. J. Horton, "Havelock School Centennial Celebration, 25 August 1961." Marlborough Historical Society, March 2003.
- 9 In general educational terms, "college" was equivalent to "high school" in the United States. It is to be distinguished from U.S. common usage of "college," meaning University.
- 10 Beasley, A. W. *The Light Accepted: 125 Years of Wellington College* (New Zealand: Wellington College, 1992).
- 11 Mezitt, Beth Pickering. Private correspondence with the author, May 2003.
- 12 Most of the letters he wrote during his college years have been preserved, and are referenced in what follows under "Letters" in the bibliography.
- 13 Pickering, W. H. *Collected Letters of William Pickering to his Father: 1923—1927*. Beth Pickering Mezitt in correspondence with the author, 2004.
- 14 Ibid.
- 15 Ibid.
- 16 Ibid.
- 17 Ibid.
- 18 Ibid.
- 19 The *Wellingtonian* was the college yearbook.
- 20 Pickering, W. H. *Collected Letters of William Pickering to his Father: 1923—1927*. Beth Pickering Mezitt in correspondence with the author, 2004.
- 21 One New Zealand pound (£) was equivalent to about five U.S. dollars (\$) at the time; also see Letters, 2004, in the Bibliography for more information.
- 22 Wellington College Archives. The *Wellingtonian*. Wellington, New Zealand: Vol. 34, Wellington, December 1925.
- 23 Horace Douslin was the brother of Kate, and technically Bert's uncle. Within the family, Will Pickering always knew him as Uncle Horace.
- 24 Pickering, W. H. *Collected Letters of William Pickering to his Father: 1923—1927*. Beth Pickering Mezitt in correspondence with the author, 2004.
- 25 The first of the colleges was Victoria College in Wellington.
- 26 Campbell, John. *Rutherford: Scientist Supreme* (Christchurch, New Zealand: American Astronautical Society Publication, 1999).
- 27 University of Canterbury Archives, 2003.

Chapter 2



The Cosmic Ray Researcher

Pasadena (1929)

Eighteen days after leaving Wellington, the *Makura* arrived off the coast of California, paused briefly to pick up a pilot, and then slipped quietly through the unspanned towering Marin Headlands of the Golden Gate to a dock near the foot of Market Street, San Francisco. It was early March 1929.

The Douslins had arranged for a car and driver to take them south to Los Angeles, a leisurely drive of some 400 miles that they thought would provide an interesting and instructive experience for their young guest from New Zealand. A week later, travel-weary and quite sufficiently impressed with the sweeping grandeur of the California landscape, the party arrived in Glendale, an outer suburb of Los Angeles.¹

The Douslins had arranged accommodation for William in an apartment house they owned near Beverley Boulevard, a middle-class locality to the west of downtown Los Angeles. He would have easy access to the elaborate network of electric rail transportation that serviced the Los Angeles area at the time, and he could live there until he found more convenient accommodations closer to the California Institute of Technology that occupied a large campus on the outskirts of Pasadena, about an hour's tram ride away.

From its humble beginnings as Throop Polytechnic Institute in the early part of the century, Caltech matured steadily under the inspired leadership of Hale, Noyes, and Millikan to reach maturity in the 1930s. Speaking of Caltech's status in the world of science, historian Judith Goodstein wrote, "Albert Einstein's visits to the Campus in 1931, 1932, and 1933 capped Millikan's campaign to make Caltech one of the physics capitals of the world."² However, dominant though it was, physics was not the only world-class research in progress at Caltech in the 1930s.

In 1932, Charles Lauritson's pioneering work with particle accelerators marked the beginning of nuclear physics at Caltech. Linus Pauling was engaged in studies

of the chemical bonds of molecules, a field that would earn him a Nobel Prize for chemistry in 1954. Charles Richter was investigating earthquake phenomena from which the universal Richter Scale for defining the magnitude of earthquakes would emerge. Under the brilliant direction of Theodore von Kármán, Caltech's Guggenheim Aeronautical Laboratory was using its wind tunnels to assist the aircraft industry with the development of improved, safer commercial aircraft such as the Douglas DC-1, DC-2, and the famous DC-3. Working with the Mt. Wilson telescope a few years earlier, Caltech astronomer Edwin Hubble had discovered the red shift spectra of galaxies and linked his observations to the concept of an expanding universe. In 1936, to great public acclaim, the huge Pyrex glass disk that would eventually become the reflector for the 200-inch Hale telescope on Mt. Palomar arrived at Caltech to begin the long, tedious, and exacting task of shaping and polishing to its final exquisite shape. At Mt. Palomar, the giant framework that would house the reflector and become "the perfect machine," was being assembled to meet the specifications of Caltech engineers and astronomers.³ And then, presiding over it all, there was Robert Millikan.

Such was the academic environment in which William Pickering chose to shape his future at Caltech in the decade of the 1930s. There were few places on Earth where such an array of scientific talent was focused in one place at one time. From the 1920s at Wellington College to the 1930s at Caltech was indeed a giant leap that, for any lesser man than William Pickering, would have posed a daunting challenge.

The school year had already begun when William arrived in Pasadena, and he was well aware that his chances of acceptance for the current year would be further diminished by any delay in submitting his application for enrollment. Nevertheless, he was determined to deal with the problem immediately. A short time later, he presented himself and his school reports from New Zealand to the student admissions office at Caltech to apply for enrollment in the electrical engineering course for the graduating class of 1932.

At that time, the Caltech school year was based on a three-term system, beginning in September and ending in June. Each term was of three months duration, and students were required to take examinations at the end of each term as a prerequisite to continuing on to the following terms. By the end of March 1929, when Pickering made his application for enrollment, first year engineering students at Caltech had already completed their second term exams for the school year that began in September 1928, and were about to commence their third and final term.

Somewhat nonplussed by the unexpected arrival of a young student from the antipodes, but nevertheless impressed with his school credentials, the Caltech authorities condescendingly offered to allow him to take the second term exams, the outcome of which would determine their response to his request for admission. If they were somewhat surprised at his ready acceptance of their offer, then they

were completely astonished at the high quality of his examination returns and they readily approved his admission to the engineering class of 1932. In April 1929, William H. Pickering became an official member of the freshman engineering class of 1932 at California Institute of Technology.

The third and final term classes began almost immediately and left William no time to seek more convenient accommodations nearer Caltech. Nevertheless, he quickly settled into a routine and, despite his problems with travel and time-consuming tasks of providing for himself, he was able to complete the school year with very satisfactory grades.

By then, he had found new accommodations in Pasadena, closer to Caltech, and became friendly with his housemate and fellow student, Gordon Bowler. They often went on outings together and shared a mutual interest in outdoor activities.

While the course work in the freshman year had been general in nature and common to all engineering students, the course work in the sophomore year became more oriented toward the electrical engineering curriculum. None of it, however, presented William with any problems. Rather, he found the course work an interesting challenge and the environment in which he now found himself not unlike what he had adapted to at Wellington College. In fact, he did so well in his term exams that toward the end of the year he attracted the attention of Caltech president, Robert A. Millikan. After a short but no doubt intensive personal lecture in the great man's study, he persuaded the young student to change his ultimate goal from electrical engineering to physics. Although Millikan's motives for his interest in Pickering were not obvious at the time and, in retrospect, may well have been self-serving, the consequence of Pickering's decision to follow his mentor's advice was to have a profound effect on the course of his subsequent career.

Pickering's sophomore year had ended on a high note. After his talk with Millikan and his decision to change his major from electrical engineering to physics he must have felt very satisfied with his new life in America, and looked forward to a relaxing summer once again.

In December 1930, William turned 20 years of age. No longer a newcomer, he was well established at Caltech and had begun to cultivate a circle of friends who, like himself, enjoyed hiking the nearby San Gabriel Mountains. He particularly enjoyed the company of Gordon Bowler on these excursions, particularly when Gordon brought his sister Muriel along on one or two occasions. He had already achieved a solid academic record and was embarking on a course that would lead him to a bachelor of science (B.S.) in physics the following year.

That year he won the Caltech Junior Travel Prize. The prize was awarded every year and provided money (\$900 per person) for two juniors to spend six months traveling in Europe. The winners for 1932 were William Pickering and Charles Jones.

Before departing, Pickering and Jones were joined by two other students who traveled at their own expense. Being already somewhat of a worldly traveler, Pickering naturally assumed the role of leader. Under his persuasive direction, the group “circumnavigated” Europe. “It was,” said Pickering many years later, “really a boondoggle for a bunch of college kids.”

Late in 1931, the Caltech administration completed construction of several on-campus residential units, or houses, for its undergraduate students. It was believed that the social interaction resulting from this form of accommodation would enhance the students' university experience, and give them a more “rounded” education to take in to the world beyond academia.⁴ Pickering took advantage of this opportunity, more for convenience than for rounding out his education, and moved into the “Dabney” residence on campus along with his friend Gordon Bowler—just in time for the start of his final undergraduate school year.⁵ The course work, physics, mathematics, or chemistry, continued to absorb his interest and he excelled in the grade ratings. He was elected senior class president and began to take a serious interest in Muriel, Gordon Bowler's attractive sister. Muriel had become a professional librarian and worked at the Echo Park Branch of the Los Angeles Central Library. Muriel was fascinated by this quiet, courteous, and very smart young Caltech student that spoke with a most unusual accent.

At the end of the school year, Pickering took the final exams, passed with honors, and graduated with a B.S. in physics (1932). The Douslins came to the graduation ceremony to wish him well and so did Muriel. He wrote his father with the good news and mentioned that he had met a fine young woman in whom he had found a great deal of common interest and whose company he enjoyed very much. The summer that followed afforded him the opportunity to see more of Muriel. Together they made hiking trips in the San Gabriel Mountains, spent time at the beach, made day trips to Catalina Island. Their relationship blossomed while they enjoyed the theater, movies, and social outings.

Soon enough the summer passed and in September 1932 Pickering was hard at work again on the first-term course for his master's degree. He had applied for and won a graduate fellowship that, together with some financial help from Horace Douslin, enabled him to get by with his living expenses. During the short Christmas/New Year break at the end of the year, he marked his 22nd birthday. Six days later on 30 December 1932, in a small private chapel at Forest Lawn, Glendale, California, he married Muriel Bowler. After a short honeymoon, the couple moved into a small, but comfortable, apartment on the edge of the lake in the Echo Park district of Los Angeles, close to Muriel's library. 1932 was a busy year for William Pickering.

The following year passed rapidly as William learned to make the personal adjustments that accompany the transition from single to married life. To all appearances he was able to deal with those personal affairs and maintain a high level

of achievement with his course work for at the end of the school year he once again graduated with honors and was awarded the degree of master of science in physics (1933). As soon as the graduation ceremony was over, he and Muriel headed for a hiking trip in the high Sierras. Refreshed in body, mind, and spirit by the pristine surroundings and the crystal-clear air of the high country, Pickering began to consider his options for post-graduate work for his doctoral thesis.

Largely as a result of Millikan's advice two years earlier, he had switched his major from electrical engineering to physics. Now, in need of a topic for his doctoral thesis, he turned to Millikan for advice. To Millikan the answer was clearly obvious—it was “cosmic rays.”

Now in his sixth year at Caltech, Pickering did what most graduate students did in those days, he sought a job to help pay his expenses and began his first research program. He had secured a Coffin fellowship that provided some financial support, and he supplemented this with a part-time teaching appointment for the undergraduate classes.

It would, he expected, take about three years to complete the research and write his thesis. Since Millikan had taken an early interest in his academic career, Pickering elected to join his cosmic-ray group. It was a measure of his potential that the world-famous scientist accepted Pickering into his circle of elite scientists. He would be one of three researchers. Carl Anderson, later to become a Nobel Prize winner, ran the cloud-chamber experiments; Vic Neher ran the electroscope experiments which Millikan himself had initiated in previous years; and Pickering would employ the recently developed Geiger tubes for his measurements. The young man from New Zealand was in heady company.



Muriel Bowler and William Pickering Pasadena, 1933 (Photo: Courtesy of Pickering Family Trust).

Cosmic Ray Researcher

In an address to the National Academy of Sciences in November 1925, Robert Millikan reported on recent studies at the California Institute of Technology of what he chose to call “cosmic rays.”⁶ The descriptive name he bestowed upon this high-energy radiation derived from his belief that they were of cosmic origin, that they rained upon Earth from sources within the Milky Way or beyond in the unfathomable reaches of the cosmos. He reasoned that the rays were produced as a result of some kind of nuclear transformation whose energy was much greater than anything hitherto observed in radioactive processes on Earth, and that the cosmic rays were indicators of these changes. Perhaps, he surmised, these processes resulted from the conversion of hydrogen nuclei to helium atoms, or the transformation of some other atomic nucleus from one form to another. In his excitement he envisioned cosmic rays as the “birth cries of infant atoms” born out of a process of fusion or electron capture. On a later occasion he referred to them as the “music of the spheres.”

In the early 1930s, Caltech, Millikan, and cosmic rays were inseparably associated with the origins of the universe in the public view of American science.

However, by the mid 1930s, Millikan's original and much publicized “birth cries of the elements” hypothesis regarding the origin of cosmic radiation and atom building had been questioned by a younger generation of scientists led by Nobel Prize laureate Arthur H. Compton. They found it to be inconsistent with the energy generated by the atom building process ascribed to it by Millikan. Rather, the much greater energy released in an “atom annihilation” process appeared to be more consistent with the energy levels required to produce the cosmic ray intensities that were then being observed by an increasing number of researchers.⁷

Although the opposing ideas of Millikan and Compton slowly merged into a state of general agreement over the next few years, much remained to be done to completely understand the origin and composition of cosmic radiation. The “latitude effect,” “atomic annihilation,” and the modifying effect of the atmosphere along with the creation of cosmic showers were topics that called urgently for further investigation. No one recognized this more than Millikan and, thus, it was no coincidence when, in mid-1933, into this void stepped a brilliant Caltech student named William Pickering who, at that time, was seeking a challenging topic for his Ph.D. thesis in atomic physics.

By the time William Pickering began focusing his attention on cosmic ray research at Caltech in 1933, many improvements had taken place in the experimental techniques employed for their study. Chief among these was the Geiger counter tube, developed by a German experimenter Hans Geiger while working with New Zealand-born Ernest Rutherford at Manchester University in England.⁸ The so-called Geiger counter consisted of a short metal tube through

the center of which passed a thin tungsten wire that was insulated from the tube by a glass seal at each end. The air within the tube was maintained at low pressure while a high electrical potential was maintained between wire and tube. The passage of a high-energy particle through the wall of the tube ionized the internal gas and resulted in a brief electrical discharge between wire and tube. The resulting pulse of current could be detected by the “kick” of some sort of electrometer instrument. A continuous record could be obtained by recording the electrometer impulses on a suitable strip chart recorder.

When two Geiger counters, one above the other with lead blocks between them, were used to detect the presence of very penetrating particles, two electrometers were used to record side-by-side tracks on a single moving chart. Comparison of the impulses indicated the presence of coincident strikes from a single high-energy particle. In this way, researchers were able to measure the absorption properties of the penetrating particles. A similar arrangement using three Geiger counters could be used to investigate the direction of arrival of the particles. Although these methods represented a considerable improvement over the primitive electroscope device used formerly, they were cumbersome, time consuming, and prone to significant errors.

By 1933 when Pickering entered the field, vacuum tubes had come into use for constructing electrical circuits that would detect coincident discharges from two or more Geiger tubes. Bruno Rossi published a seminal paper in 1933 in which vacuum tube coincidence circuits were used to measure the responses from three counters that were set up in a vertical arrangement to reduce the occurrence of accidental coincidences. His paper attracted a great deal of attention among cosmic ray investigators of the time and demonstrated the advantages of Geiger tubes and coincidence circuits over former methods using the electroscope. It became the way of the future and Pickering decided to start there.⁹

Despite their promise, however, there were inherent problems with the early Geiger tubes and coincidence detectors and Pickering addressed those first. The most important deficiency related to errors in the cumulative counting function and these, in turn, depended upon the stability of the vacuum tube coincidence counters and the stability of the high-voltage potential applied to the Geiger tubes. Pickering reasoned that since the observed coincidences occurred at the rate of a few tens per hour, it would take a very long time to accumulate sufficient counts to reduce the probable error to an acceptably low value. A quick calculation told him that it would take roughly 1,000 hours of continuous recording to accumulate 10,000 counts, the minimum required to achieve a problem error of 1 percent. The long term stability of existing coincidence circuits and high voltage circuits was not good enough to guarantee that level of accuracy in the overall count values, and could well lead to erroneous conclusions in the ultimate evaluation of the experimental results.

When he first started constructing his own Geiger tubes, Pickering followed the example of current investigators. The best of these designs used a central wire of tungsten or copper passing through a brass tube, the interior surface of which was coated with soot. These tubes were unreliable and not uniform in performance and unsatisfactory for lengthy experiments involving coincidence counters. Within a short time Pickering found a better way to build a Geiger counter tube. In his design, a short copper tube, its interior surface made as smooth as possible, supported a central axial tungsten wire by glass seals at each end. After heating to remove traces of grease and create a thin oxide coating, the assembly was washed with dilute nitric and finally rinsed off with distilled water. The counter was immediately evacuated and filled with clean dry air or a mixture of argon and air at low pressure.¹⁰ The completed counters, about 1 inch in diameter and 5.5 inches in length, overcame all of the deficiencies noted in previous designs and proved very satisfactory in the intensive series of laboratory and field experiments to which Pickering eventually subjected them.

By 1933, when Pickering became involved, the problem of reliably and accurately recording the occurrence of cosmic ray coincidences from Geiger tubes had been studied by numerous investigators and several circuits had been noted in the scientific journals. Of these, the preferred method, due to Rossi,¹¹ used a triode vacuum tube connected to each Geiger tube to detect the passage of an ionizing particle through the tube. The output current from each of the three triodes passed through a common resistance to develop a voltage sufficient to drive an output counter triode into conduction only when all three Geiger tubes were triggered simultaneously. Impulses of current flowing through the counter triode were counted cumulatively by an electro-mechanical counter. Pickering soon saw the deficiencies in this type of circuit and set about correcting them. By substituting thyratron¹² tubes for the triodes in Rossi's circuit, he overcame some of the problems but the current in the thyratrons was difficult to quench rapidly and the counters were expensive to build. Meanwhile, a new type of vacuum tube had come on the market, principally to support the explosive growth in the domestic radio receiver field. It was known as the pentode.¹³ Investigators at the Franklin Institute had drawn attention to the possible application of this type of tube to the original Rossi circuit. In pentodes, the anode current cut off very sharply when the grid voltage reached negative four volts, but was restored as soon as the grid voltage returned to its former level. Since Geiger tube impulses always generated much larger pulses than this, even the smallest Geiger impulses could be detected. The impulse current from three or more pentodes connected to a common output resistance generated a voltage pulse of sufficient amplitude to trigger a thyratron connected to an electro-mechanical counter arrangement as shown in Pickering's original circuit diagram.^{14,15,16}

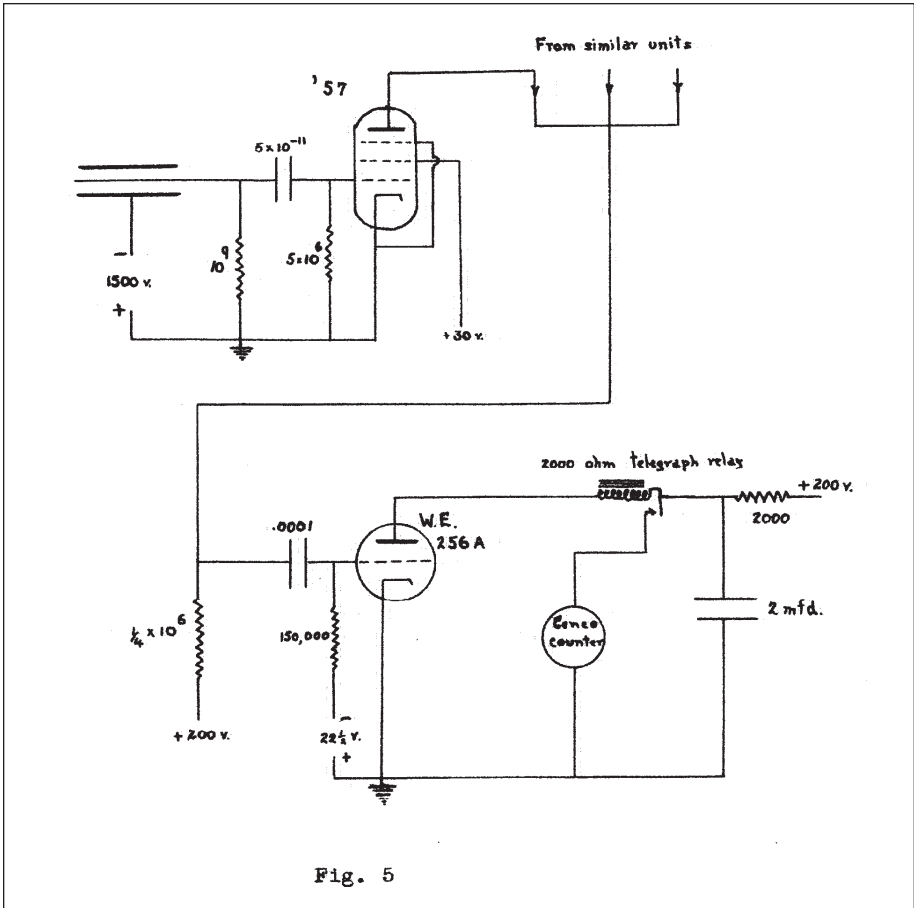

Fig. 5

William Pickering's original thesis; circuit diagram for a coincidence counting instrument for Geiger counters: 1936 (Photo: Courtesy of Pickering Family Trust).

With this arrangement he could count up to 1,000 random impulses per minute, more than sufficient for his experiments. In addition to being reliable, the instrument could be readily adapted to portable form, an important consideration in view of the field experiments that he planned. Although the instrument was further improved in due course (to reduce its resolving time), this was the basic instrument with which he began to accumulate the experimental data that he believed would contribute significantly to our understanding of the origin, composition, and dispersion of cosmic rays. The shadow of the great Millikan hovered over the young scientist as he began to collect his experimental data among the scientific elite at Caltech.

Pickering began by establishing the scope of his investigations. The Geiger counter, he said, naturally lent itself to the investigation of several different types of problems.

There were directional effects in which two or more counters were "arrayed" with their axes parallel, with no material between them. Coincident discharges of the Geiger tubes would then be due to the passage of a single ionizing particle through the set of counters. The direction of incidence would correspond to the solid angle subtended by the array.

If various amounts of dense solid material were placed between the individual tubes in an array, the energy of the rays could be deduced by correlating the observed coincidence rate with the density of the intervening material. When a thin lead plate was placed above three counters arrayed at the corners of a triangle, the observed coincidences would be due to at least three separate ionizing particles emerging, in widely divergent paths, from some point in the intervening lead plate. It would signify the detection of a "cosmic shower." The occurrence of cosmic showers could also be observed in a proximate cloud chamber by using the coincidence signal from the counter to trigger the cloud chamber mechanism.

Finally, there was the controversial "latitude effect," or geographical distribution, of the radiation that could be studied with a portable version of the instrument wherein the Geiger tubes were placed close together to register rays from as large a solid angle as possible.

All of these investigations were possible with his new instrument; with enthusiasm and vigor, Pickering set out to attack them all.

With Geiger tubes suitably arrayed to form a cosmic ray telescope, he investigated the Sun and its surrounding area, and a large region of obscuring matter, several degrees in width, near the constellation of Cygnus. Although the solar experiments were unsuccessful, the observations of Cygnus showed no significant change in the coincidence rate that could be attributed to obscuration of cosmic rays by the dark matter.

Pickering then turned to experiments involving the penetrating part of the radiation.¹⁷

Previous experimental work by Rossi in 1933 had led to the conclusion that this part of the radiation consisted of high-energy charged particles. With great tact, Pickering pointed out that: "This conclusion is at variance with preconceived notions of the character and properties of such high energy radiation," and that, ". . . it would be of interest to see whether any alternative explanations of this result are tenable."

In a lengthy and complex series of experimental runs involving many different arrangements of coincidence arrays and lead blocks of various thickness, Pickering concluded that: "There is no direct evidence as to the nature of the primary penetrating radiation. However, it can be asserted that this

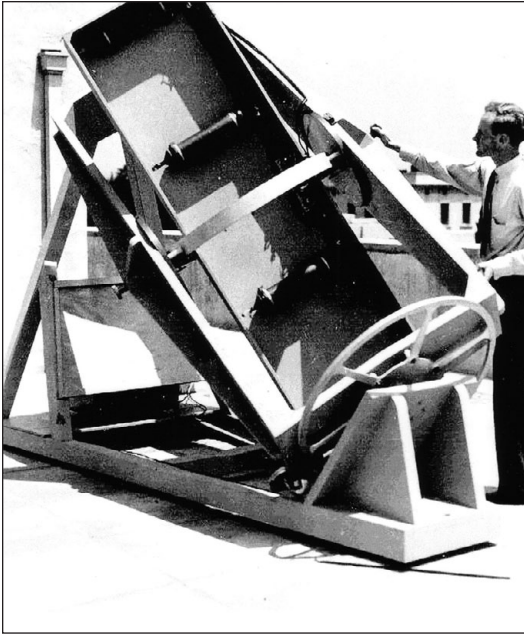

William Pickering observing solar radiation with his cosmic ray telescope at Caltech, circa 1934 (Photo: Courtesy of Pickering Family Trust).

radiation, for the most part, penetrates lead without appreciable deviation.” Occasionally, it generated widely divergent secondary radiation. All of his Geiger counter experiments, he said: “. . . are consistent with the hypothesis that the primary is a very penetrating particle.”¹⁸

The existence of cosmic ray showers had been known for some time and, indeed, had been discovered by experiments using Geiger tubes arranged in a horizontal array. Horizontal

coincidences pointed to the occurrence of a group of particles emanating simultaneously from a small region in material above or below the array. The shower patterns were very evident in cloud chamber photographs triggered by Pickering’s coincidence instrument, and careful interpretation of these images provided a starting point for his investigations into the shower-producing mechanism. For his experiments he placed plates of lead, iron, or aluminum of various thicknesses above and below two or more horizontally arrayed Geiger tubes. Supported by a theoretical analysis, he evaluated the observed coincidence rates as a function of the experimental parameters; that is, the thickness and type of material. Among the key findings¹⁹ he found that:

- a. Shower particles have a penetrating power that, on the average, is less than that required to penetrate 5 cm of lead plate.
- b. Showers are caused by *groups of shower-producing photons* rather than single photons that give rise to a series of showers.
- c. Showers observed under large thicknesses of lead are caused by photons that are produced in the lead by an (high-energy) incoming ionizing radiation.

Next, Pickering turned to the geographical distribution of the showers. Again exercising his native tact he began:

It has been known for a number of years that the intensity of cosmic radiation is less in the equatorial band than at other points on

the Earth's surface. This effect has been explained as due to the Earth's magnetic field deflecting incoming particles away from the equator." This raised the question: "Is the shower producing radiation [also] affected by the magnetic field of the Earth?"²⁰

Pickering set out to find an answer to that question based on the following reasoning:

If the primary is a charged particle with an energy small enough to be deflected by the Earth's magnetic field, then there will be a latitude effect in the number of showers emerging from a given lead plate. If the primary is uncharged, or, if the photon is itself the primary, then there will be no change in the number of showers with latitude.

To investigate the matter he modified his shower coincidence detection equipment to run from a shipboard, direct-current power source and mounted the Geiger tubes on a gimbaled frame to counteract the ship's rolling. Then, with his scientific equipment assembled into a convenient portable arrangement and his new wife Muriel for company, he took a ship from Los Angeles homeward bound for Wellington, New Zealand. During the voyage he would measure the coincidence rate for high-energy particles with the Geiger tubes in vertical array and the shower components with the tubes in triangular array, alternating runs between the two configurations. The ship's log would provide him with latitude and barometric data.²¹

Although a considerable amount of data was collected it was not as consistent, nor as accurate, as he had hoped due to experimental problems related to typical shipboard conditions like vibration, DC power fluctuations, radio interference, etc. Also, being on a north-south course most of the time, the ship's rapidly changing latitude did not allow sufficient time at any given latitude for the accumulation of a large coincidence count. Nevertheless, when the data was evaluated, it did show a latitude effect amounting to about a 15 percent reduction at the equator for the vertical components and about one half of that for the showers. With perhaps an eye to future work, he observed that these experiments had not been extensive enough to get a complete picture of the nature of primary showered producing radiation and suggested that more data were needed, specifically in regard to the effects of high altitude and latitude changes on cosmic ray intensity.²²

So it was done. Doing the experimental work and writing it up had taken about three years, but at the end it carried him forward to a just reward. Caltech recognized his work as a unique and valuable contribution to the field, and conferred upon him the degree of doctor of philosophy, *cum laude*. It was indeed a high honor and a great distinction for the young scientist from New Zealand.



California Institute of Technology, Pasadena, circa 1930 (Photo: Courtesy of Pasadena Museum of History Archives, Photo number S-4-22).

During the short time that he spent in New Zealand in 1936 while engaged in the search for the “latitude effect” for his thesis program, he had looked into the possibility of ultimately making a career in the burgeoning hydro-electric power industry. For the past several years, New Zealand had been “electrifying” the entire country, and there appeared to be potential openings for engineers in dam construction, and electric power generation and distribution systems. However, by the time Pickering became interested in job-seeking in New Zealand, the worldwide depression had begun to adversely affect the country’s economy and he was unable to find the kind of position that was he seeking. Fortunately, before he left Pasadena, Caltech had already offered him a position as an instructor in its department of electrical engineering under Professor Royal Sorenson, and it was to this position that he now decided to return. The couple arrived back in Pasadena at the end of the year (1936) and he took up his teaching duties in the electrical engineering department shortly thereafter. Ten years later, William H. Pickering would become a full professor.

In the late 1930s, the Pickering family moved to a house in the Pasadena city area near the sprawling Caltech campus. At that time the campus included a sizable grove of orange trees where, in later years, the beautiful Athenaeum would be built and where a short 220 kilovolt electrical transmission line was built for

Professor Royal Sorenson to carry out his pioneering research on high-voltage electric power transmission systems. The blend of rural ambience and modern technology created a stimulating environment for the pursuit of science and higher education. As one of Sorenson's young, new instructors, Pickering was required to adhere to the basic electrical engineering curriculum, but his growing interest and, at the time, unique experience with electrical counting circuits persuaded him to introduce these new techniques into the agenda of classical power engineering principles advocated by the head of the department. Within a few years, the principles and techniques that had captured the young scientist's attention as an adjunct to his cosmic ray investigations grew to become an important new field of electrical engineering known as electronics.

Meanwhile, in the loosely knit faculty organization of the time, Pickering continued to work as a valued member of Millikan's cosmic ray research team. He had become acquainted with co-worker Victor Neher in previous years while working on his thesis and, although Neher's special expertise lay with the electroscopes experiments, they shared a common interest in Millikan's theories of cosmic ray generation, and their experimental techniques complemented one another in making observations in the field. Neher had worked with Millikan on electroscopes observations of cosmic ray intensity at altitudes of 10,000 to 12,000 feet in the Sierra Nevada where temperature control and lightweight packaging were significant factors in the design of the experimental equipment. If Pickering was the coincidence counter and electronics expert, Neher had the experience when it came to lightweight components, temperature control, primary power sources, and packaging.

When Millikan's ideas called for observations at even greater altitudes, beyond the sensible influence of atmosphere, his experimental team of Neher and Pickering turned toward the use of hydrogen filled balloons as the lifting medium and airborne Geiger tubes and instruments with radio transmitters as the observing medium. The new challenge fit perfectly with the complementary skills and common interest of the two scientists. Between them, they quickly developed new Geiger tubes, a suitable high-voltage regulated power supply for the Geiger tubes, the necessary miniaturized coincidence counter, radio transmitter, and antenna—all of it integrated into a light-weight, temperature-controlled flight package called a radio-sonde.^{23,24} The balloons and gas filling equipment, VHF receiver, tracking antenna, continuous paper tape recorder, and primary power generator completed the mobile field installation.

After a few test flights to checkout the performance of the airborne package, Pickering and Neher were satisfied that they had the necessary equipment to carry out cosmic ray intensity observations in the stratosphere to altitudes of 80,000 feet and, perhaps, beyond. Moreover, the data could be returned to Earth for recording in "real time." Except for reasons of economical reuse, it was no longer necessary to recover the airborne package to retrieve the data.

Quietly and unobtrusively, a new technology, remote sensing with data retrieval by radio-link, had come into being. Given an appropriate sensing instrument, scientists would now be able to make observations and retrieve their data from places where a human observer could not go. No one, not even Millikan, might have imagined where this idea would lead two decades later.

As Millikan began to embrace the concept of cosmic radiation generation by the annihilation of certain atoms, he reasoned that it should be possible to calculate the energy of the annihilation process from the rest mass of the atoms involved in the annihilation process. Earth's magnetic field, he believed, would act like a huge spectrometer to the incoming cosmic radiation and create line spectra, dependent upon the strength of the magnetic field at different latitudes and the energy of the cosmic radiation. By knowing the cosmic ray intensities at various latitudes, he could calculate the energy required to reach each "latitude of observation" and relate that energy back to its original source, the energy of annihilation.²⁵

In addition to this theory, loosely described as the "latitude effect," Millikan had for some time held to a theory that came to be known as the "longitude effect," and along with Neher had published an article on this hitherto unsuspected effect in 1934.²⁶ The basis for this theory related to the asymmetry of Earth's magnetic polar axis with respect to Earth's geographic polar axis. If this was taken into account, Millikan believed, the spectrographic effects that he sought would also vary with longitude.

To maximize these effects, he planned to make measurements at different latitudes along two widely separated longitudes. For practical reasons, he chose lines of longitude running through the continents of India and North America. He intended to begin with the observations in India and to follow those with observations in North America. It would be a beautiful demonstration of his concept of the theory of particle annihilation.

In 1939, Millikan organized a small expedition to India to demonstrate his theory. Led by Millikan himself, the expedition would include Victor Neher and William Pickering. For Pickering however, the invitation to join the expedition to India created somewhat of a dilemma for, by then, Muriel had given birth to their first child and she was not disposed to remain alone in Pasadena while he traveled overseas on a scientific jaunt of indeterminate duration with the Millikans. It was decided that Muriel and the baby would return to New Zealand to stay in Christchurch with her father-in-law while her husband was away.

However, the following month, shortly after the party reached Sydney, Australia, World War II began with the horrific news of England's declaration of war on Germany. Undismayed, Millikan decided to press on with the original travel plan and sailed for Singapore. Under the wartime exigency, their original ship would take them no further. After a week in Singapore, the party managed to find passage on a dirty old British freighter and, with some trepidation, set

sail for Calcutta, India, via Rangoon, Burma. Despite the potential hazard of sailing aboard a British freighter in wartime, the party reached its destination without further incident.

The observations began in the Indian city of Agra. Visits to Peshawar in the northwestern territory and finally down to Bangalore in the southern part of the continent completed the tour. The observations covered about 22 degrees of latitude within a few degrees of a single line of longitude, a sufficient range of latitude to verify the existence of radiation from different atoms being annihilated according to Millikan's theory. Throughout the tour, the Indian government's meteorological service provided the party with supplies of hydrogen for the balloons, recovery services, and weather-related details. Three months later, replete with a surfeit of science data, the party began its return journey to the U.S. by a circuitous route through Hong Kong, Yokohama, and Hawaii.

William left the ship in Hawaii to await the arrival of Muriel on her journey from New Zealand. On their return to Pasadena in mid-1940, the Pickering family resumed the daily routine of life in the academic circles of Caltech faculty and, untouched by the cataclysmic events developing in Britain and Europe, set about raising a child. Pickering meanwhile resumed his teaching duties and began reducing the data from the high altitude flights in India.²⁷

Satisfied with the success of the India experiments, Millikan now began planning a similar suite of measurements with his high-altitude balloons on a north-south line across North America. The new measurements would extend from southern Mexico to northern Canada beginning in the Mexican cities of Monterey and Acapulco. Since the latitudes of these two sites fell roughly between those of the northernmost and southernmost sites of the Indian tour, data from them would serve nicely to fill the data gaps in the Indian measurements.

Once again, Millikan invited Pickering and Neher to accompany him and, as before, Mrs. Millikan went along with him. This time though, Pickering also took his wife along on the trip which, they anticipated, would last just a week or two. It all seemed like a great adventure as the expedition set off from Pasadena early in December 1941.

They crossed into Mexico on 5 December and drove south to Monterey, a relatively short journey of about 200 km (120 miles), where they soon found a convenient hotel and suitable site for launching and tracking the balloons. Two days later they launched the first balloon and tracked it for the full duration of its flight. Pickering's radio-sonde worked well and he was able to record good data throughout the entire flight. Well satisfied with their day's work they returned to the hotel to be met by a thoroughly alarmed Muriel who, with her limited ability in Spanish, had just learned from the local Mexican radio that the Japanese had attacked Pearl Harbor in Honolulu. It was 7 December 1941 and now America, too, was at war.

For the second time, Millikan's cosmic ray expedition was caught up, far from home, in the repercussions of a world-wide war. Not without some anxiety, they resumed the balloon flights as planned, collected their data, and apprehensively returned to Pasadena to begin reducing the data and writing the papers.^{28,29} They soon found, however, that the local world as they had known it a scant few weeks earlier had changed, and not for the better.

World War II (1942–1944)

Pickering never again took an active part in cosmic ray research. Within a few short months his unique talents were redirected toward the nation's effort to defeat Japan and, in so doing, set him upon a course that would ultimately lead him away from academia and pure scientific research to the cutting edge of applied technology and big science on the grandest scale.

The outbreak of war in Europe had prompted Pickering to file the papers for naturalization as soon as he returned from India. Hitherto, this had not been a matter of any importance in the academic atmosphere in which he moved. But suddenly the world had changed, and the matter of U.S. citizenship took on a measure of considerable significance for him—much greater significance than he could possibly have imagined in the light of what was to happen to the world he moved in, just over a year later. The proceedings were quite straightforward; the U.S. District Court in Los Angeles admitted him to citizenship of United States on 14 February 1941.³⁰

As Caltech refocused its powerful research and development capabilities on the war effort, Pasadena developed into a center for industrial research and the manufacturer of precision instruments for scientific research and electronic applications. The national war effort also included the education of vast numbers of servicemen and women in scientific and technical fields beyond the normal high school level and it was here too that the Caltech played a major role.

Very soon after the war started, Caltech moved to a 12-month schedule to support an officer-training program for the U.S. Navy. Named the V-12 program, the courses were designed for civilians from all walks of life who were entering the Navy at the officer level and requiring higher level training in electrical engineering, physics, and mathematics to equip them for further specialized training in Naval schools. As part of Caltech's V-12 program Pickering extended these classes to include electronics, a topic that wartime concerns with radio communications; radar and direction finding, and sonar, had escalated to prime importance. Pickering's demonstrated preeminence in that field placed his services in great demand.³¹

Caltech also became involved in another program to meet the requirements of wartime industry. This was becoming a high-tech war and many of the civilian leaders of industry needed some basic knowledge of science and

mathematics at the advanced high school level to properly manage the vast numbers of wartime factories, principally aircraft related, that were springing up all over Southern California. The program was called Engineering, Science, and Management for War Training (ESMWT), and was conducted by special instructors, trained and organized by Caltech, throughout the Los Angeles area. A substantial effort in its own right, the ESMWT was part of a much larger program to harness the scientific talent of the country to support military needs that had been established at the national level by Vanevar Bush, director of the National Defense Research Committee.

It was during the war years, [Pickering recalled] about 1943–1944, that the Japanese bomb-carrying balloons began to appear over the United States. They called them a ‘Vengeance Weapon’ and had public launchings off the beaches in Japan. They were carrying bombs to the heartlands of America the Japanese propaganda machine proclaimed. It was a clever idea with a balloon designed to reach about 30,000 feet the jet stream would eventually carry it to the United States where instead of dropping sandbags it would drop incendiary bombs to set fire to the forests. A number of these things were recovered between California and Florida because the self-destruct mechanism failed and brought to Caltech [to me] for analysis to find out how it worked because of my association with balloons and electronics. We soon found a fundamental flaw in the design that caused the battery to freeze up and that caused the self-destruct device to fail. One Friday afternoon I was called to the Caltech warehouse where one of these things had been brought in. It was complete, with the self-destruct explosive just sitting there ready to blow-up the warehouse and me with it. I called the Army to come and safe [*sic*] it before I did any more investigation, but it was a scary experience.

Busy though it was with the normal influx of students and the V-12 and ESMWT programs, Caltech was also involved during the war years with two other programs of great national importance but of quite a different type. One of these was for the U.S. Navy and the other for the U.S. Army. Eventually, Pickering became deeply involved with the latter and it is to this phase of his life that we now turn.

Endnotes

- 1 Mudgway, Douglas J. Oral history interview with William H. Pickering: Pt. 3. Pasadena, California, January 2003.
- 2 Goodstein, Judith R. *Millikan's School: A History of the California Institute of Technology* (New York: Norton, 1991).
- 3 Ibid, Photo: Dedication of 200-inch telescope.
- 4 Edelson, David. "Pre-history of Caltech's South Residence Houses." Pasadena, California: California Institute of Technology; available online at www.ugcs.caltech.edu: 2004.
- 5 Mudgway, Douglas J. Oral history interview with William H. Pickering: Pt. 3. Pasadena, California, January 2003.
- 6 Kargon, Robert. *The Rise of Robert Millikan: Portrait of a Life in American Science* (Ithaca: Cornell University Press, 1982).
- 7 Ibid.
- 8 Campbell, John. *Rutherford: Scientist Supreme*. Christchurch, New Zealand: American Astronautical Society Publication, 1999.
- 9 Pickering, William H. "A Geiger Counter Study of the Cosmic Radiation." Pasadena, California: California Institute of Technology, 1936.
- 10 Gas pressure was 5 cm, equivalent to about 3% atmospheric pressure.
- 11 Rossi, Nature 125, 1930, p. 636.
- 12 Thyatron was a mercury or argon filled vacuum tube that could be triggered in conduction by applying a voltage pulse of specified amplitude to its grid. Once triggered the grid no controls the current flow through the tube.
- 13 The pentode had three grids between cathode and anode whereas the triode had only one.
- 14 Neher, H. V. and W. H. Pickering. "Modified High-Speed Geiger Counter Circuit." *Physical Review*, Vol. 53, 15 February 1938, p. 316.
- 15 Neher, H. V. and W. H. Pickering. "A Circuit for Rapid Extinction of the Arc in a Thyatron." *Review of Scientific Instruments*, Vol. 9, June 1938, pp. 180—182.
- 16 Neher, H. V. and W. H. Pickering. "Two Voltage Regulators." *Review of Scientific Instruments*, Vol. 10, February 1939, pp. 53—56.
- 17 Cosmic rays comprised two classes of radiation, primary and secondary. Primary radiation had great penetrating power and was believed to consist of high-energy particles of extra terrestrial origin. Secondary radiation was shower-like in nature and was thought to be produced as a product of multiple collisions of the primary radiation with atoms in Earth's atmosphere.
- 18 Pickering, William H. "A Geiger Counter Study of the Cosmic Radiation." Pasadena, California: California Institute of Technology, 1936.
- 19 Ibid.
- 20 Ibid.
- 21 Neher, H. V. and W. H. Pickering. "An Attempt to Measure the Latitude Effect of Extensive cosmic Ray Showers." *Physical Review*, Vol. 58, 15 October 1940, pp. 665—666.
- 22 Pickering, William H. "A Geiger Counter Study of the Cosmic Radiation." Pasadena, California: California Institute of Technology, 1936.
- 23 Neher, H. V. and W. H. Pickering. "Light Weight High voltage Supply for Geiger Counters." *Review of Scientific Instruments*, Vol. 12, March 1941, pp. 140—142.

- 24 Neher, H. V. and W. H. Pickering. "A Cosmic-Ray Radio Sonde." *Review of Scientific Instruments*, Vol. 13, April 1942, pp. 143—147.
- 25 Millikan, R. A., H. V. Neher, and W. H. Pickering. "Hypothesis as to the Origin of Cosmic rays and its Experimental testing in India and Elsewhere." *Physical Review*, Vol. 61, 1—15 April 1942, pp. 397—407
- 26 Kargon, Robert. *The Rise of Robert Millikan: Portrait of a Life in American Science* (Ithaca: Cornell University Press, 1982), p.160.
- 27 Neher, H. V., and W. H. Pickering. "Results of a High Altitude Cosmic Ray Survey Near the Magnetic Equator." *Physical Review*, Vol. 61, 1—15 April 1942, pp. 407—413.
- 28 Millikan, R. A., H. V. Neher, and W. H. Pickering. "Further tests of the Atom-annihilation Hypothesis as to the Origin of Cosmic Rays." *Physical Review*, Vol. 63, 1—15 April 1943, pp. 233—245.
- 29 Millikan, R. A., H. V. Neher, and W. H. Pickering. "Origin of Cosmic Rays." *Nature*, Vol. 151, 12 June 1943, pp. 663—664.
- 30 Mezitt, Beth, Pickering. Private correspondence with the author, August, 2005.
- 31 Mudgway, Douglas J. Oral history interview with William H. Pickering, Pt. 4. Pasadena, California, January 2003.

Chapter 3



The Cold War Warrior

Jet Propulsion

In the 1930s, the Guggenheim Aeronautical Laboratory at the California Institute of Technology (GALCIT) was one of the world's leading centers for aeronautical research. Nurtured by its brilliant Hungarian-born director Theodore von Kármán, student engineers studied topics in the field of classical aerodynamics such as wing lift and drag, stability of moving bodies, and propeller efficiency. Their thoughts and goals were focused on raising aircraft speeds above 300 miles per hour (mph), improving the safety of air flight, and reducing the costs of air transportation. Wind tunnels were the essential bases for their experiments. In these endeavors they were spectacularly successful, and many of von Kármán's graduate students went on to become giants of the burgeoning American aircraft industry.

A brilliant student among the class of 1936, Frank J. Malina, took a different direction, one that eventually connected with that of another outstanding Caltech physics graduate named William Pickering. Previously, Malina had gone to von Kármán with a far-out proposal for a doctoral thesis. He proposed to investigate the problems of rocket propulsion and the aerodynamic characteristics of atmospheric sounding probes that would be flown to extremely high altitudes by means of rocket motors. Von Kármán was no stranger to the basic ideas of rocket propulsion. In the early 1920s, several years before he came to Caltech, he had listened with interest to the proposals of German experimenters in rocket propulsion, and he was familiar with more recent reports of promising rocket propulsion experiments coming out of Vienna. Von Kármán viewed rocket propulsion as an irresistible new challenge and lost no time in encouraging young Frank Malina to go ahead.¹

To gain an understanding of the basic principles of rocket motor design and performance, he first built a small rocket motor powered by a mixture of liquid oxygen and methyl-alcohol and set it up in a secure test stand fitted

with pressure gauges, flow meters, and thrust measuring devices to measure critical data during each test firing. Obviously such a dangerous experiment could not be conducted in a Caltech with people nearby. After much searching, the group found a suitable site in a dry canyon called Arroyo Seco, a few miles from Pasadena, in the foothills of the San Gabriel Mountains. There, on 31 October 1936, protected by sandbags from a potentially damaging explosion, Frank Malina and his colleagues conducted their first rocket motor tests. Although these tests were primitive when judged by later standards of rocket motor performance, they were a major achievement for the time, and the event and its location became permanently associated with the subsequent history of the area.

By the beginning of 1938 they had accumulated sufficient data for two of them, Frank Malina and Apollo Smith, to present a paper titled, "Analysis of the Sounding Rocket," to a convention of the Institute of Aerospace Science in New York. Later, when the paper was published, it caused a media sensation in the leading papers of New York and Los Angeles where writers fantasized about moon voyages and rocket-powered airplanes.²

A few months later, Caltech received an informal visit from General H. H. "Hap" Arnold, then commander of the U.S. Army Air Corps. Always a strong advocate of the application of new scientific discoveries to military purposes, Arnold liked to keep up to date with what was happening in the world of advanced technology. At Caltech, he was particularly attracted by the ideas and demonstrated progress of von Kármán's rocket group. Later, when he met with the Committee for Air Corps Research³ to recommend topics for future research, he placed particular emphasis on the application of rockets for accelerating the military's take-off aircraft based on the ideas sparked by his visit to Caltech. It was a wild idea, but one that held immense potential for the Air Corps if it could be turned into a practical system. In the end, the committee agreed to provide funding for furthering rocket research

at GALCIT with a specific goal of "developing a rocket motor that would be immediately applicable to aeronautical purposes."⁴



Bare necessities: By 1942, GALCIT had constructed some semblance of basic rocket motor test facilities in the Arroyo Seco (Koppes: Wartime foundations) (Photo: NASA/JPL-Caltech Archives, Photo number 1).



Rapid departure: "None of us had ever seen a plane climb at such a steep angle," said von Kármán following the first demonstration of rocket-assisted take-off in America at March Field, California, 12 August 1941 (von Kármán, p. 184) (Photo: NASA/JPL-Caltech Archives, Photo number P381-30).

"Rocket science," no longer a topic of intriguing scientific interest, had become a viable technology whose immediate application was firmly vested in the military.

When the GALCIT rocket group accepted the Air Corps contract it was immediately confronted with the problem of how to make a small, solid fuel motor burn smoothly for 10 to 12 seconds without blowing up. And how could such a motor safely attach to an aircraft to accelerate its take-off run without damage to plane or pilot? Malina turned to von Kármán for help.

Together, they developed a set of mathematical equations that described the physical processes involved in the burning of solid propellants in a constricted combustion chamber. Armed with a better understanding of the interactions of high temperatures, high pressures, and propellant burning areas; and encouraged by additional funding from the Air Corps, the group resumed its experiments in Arroyo Seco. Eventually they found a way to control the rocket burn rate and duration, and verified the design in "static tests" with the aircraft anchored to the runway. They were ready for flight testing.

The first successful rocket-assisted take-off with a small aircraft took place in August 1941 with Lt. Homer Bouchey as the pilot. Less than a year later, the group demonstrated rocket-assisted take-off with a 20,000 pound Douglas A-20 bomber.

In ecstatic words von Kármán saw the event as ". . . the beginning of practical rocketry in the United States."⁵ "If we could make a small effective rocket for lifting a plane, then why could we not build a rocket that would lead us into high altitudes and eventually into space?" von Kármán wondered. In those two observations, von Kármán voiced his premonitions for the future with uncanny accuracy.⁶

From about 1940 the activities taking place in and around the shabby buildings set deep in the stony, bleak Arroyo Seco were blanketed in secrecy. No longer a low-key, loosely run field station for a few highly motivated and slightly crazy Caltech students who were testing some far-out science fiction invention; the GALCIT site had become a closely-guarded military facility engaged in work of national importance.

Rocketry became a burgeoning new technology for the nation, and the few nondescript buildings on that improbable site were soon replaced with a great new facility from which sprang the technology that led the nation into space. It would be known as the Jet Propulsion Laboratory. But first, there was a war to be fought and won.

Early in 1943, while the GALCIT rocket group continued its basic research work-up in the Arroyo Seco, the U.S. Army Air Corps began to worry about intelligence reports from Europe that suggested the Germans were developing large rocket-propelled missiles whose range far exceeded anything that was previously known to exist in Germany, or elsewhere. Privy to this information, von Kármán readily acquiesced when the Army Department of Ordnance asked him for a proposal to expand GALCIT's existing rocket engine research program to include the development of long-range rockets.

After some internal exchanges within the Army, the Department of Ordnance accepted the von Kármán proposal with the recommendation that Caltech broaden its research and development program to include not only the rocket motor, but also the development of a prototype guided missile.⁷ Although the board of trustees realized that this would carry Caltech into unfamiliar areas of technology, they accepted the challenge and in February 1944 approved a contract with Army Ordnance for a wartime program of guided missile development.

Almost immediately, the GALCIT project was reorganized to accommodate the new change in direction. Additional staff, many from Caltech, was brought in, new facilities were planned, and the facility received a new name. Henceforth it would be known as the Jet Propulsion Laboratory of the Guggenheim Aeronautical Laboratory of the California Institute of Technology, or JPL/GALCIT for short. Operating under its new title, JPL officially began work on guided missile development on 1 July 1944. Owned and managed by Caltech, it had become a contractor for the U.S. Army. However, despite its relationship with the Army and indeed its dependence on the Army for its core programs, JPL retained close ties to Caltech and was able to call upon the Caltech faculty for expert advice and assistance in technical areas beyond its own range of experience.

Spurred by wartime urgency and backed by ample funding from the Army, new laboratories and buildings to house administration and technical staff soon replaced the original dilapidated buildings in Arroyo Seco. A supersonic wind tunnel and several rocket test stands were also added to the facility.

Initially, the new JPL was organized along the lines of its parent organization Caltech, under the chairmanship of von Kármán. However, when von Kármán left Caltech at the end of 1944 to join a scientific advisory board for the Air Force in Washington, the Caltech administration created an executive board to run JPL and appointed Malina to the position of acting director.⁸

Undeterred by the challenge of overtaking the best that Germany could produce, the young men at JPL embarked on a crash program that called for the development of a small, short-range, solid-propellant missile they would call "Private." This would be followed by a heavier longer range version that would include a guidance system and a liquid-propellant engine. That version they would name "Corporal." Later, improved versions would become "Sergeant." In this way the program would progress in stages to reach the ultimate level of performance required by the Ordnance/Caltech (ORD/CIT) contract.⁹

As the work on Private A gathered momentum, it became apparent to Malina and his ORD/CIT team that, impressive though it was, his existing organization was deficient in two areas, both of which would become essential to the successful completion of the Private A program. The areas of concern were test instrumentation and flight testing. His engineers and scientists needed a better way to know what was really happening during engine test firings, for example, and they needed accurate records that could be analyzed after the flight tests were completed. Expert help was needed, and needed fast, to keep up with the frantic pace of the Private program. Malina turned to his mentor, Professor von Kármán.

Von Kármán remembered the smart young physics graduate from New Zealand who had distinguished himself working with Millikan on cosmic ray research just prior to the war. He had joined the faculty in the department of electrical engineering, recalled von Kármán, and was teaching electronics in the V-12 naval officer's training program as part of the Caltech war effort. Von Kármán was aware that, from time to time, Pickering had been called over to Arroyo Seco to bring his experience with electronics and remote control devices to bear on related problems in rocket development. Pickering knew most of the people over there and was highly regarded for his experience, and for his innovative approach to difficult technical problems. Von Kármán sent Malina over to talk to Pickering.

Pickering agreed to join Malina's team at JPL on a part-time basis while he continued his commitments to the V-12 Navy program at Caltech. He was to set up a new section at JPL to provide remote control and telemetry instrumentation support for the ORD/CIT project as a part-time section chief under the direction of Malina. It would be a loose, informal arrangement in which Pickering would remain on the Caltech teaching staff, but would devote part of his time, as required, to working JPL's problems.

It was summer 1944 and von Braun's V-2 missiles, the product of many years of development and testing in the German rocket laboratories led by Wernher von Braun, were raining down on London, England, and, although the world did not yet know it, the war in Europe had just over a year to run to its desperate conclusion.

Before starting in at JPL, Pickering traveled back to the east coast to visit the Massachusetts Institute of Technology (MIT) and the Aberdeen Proving Ground (APG), two major centers of advanced technology related to radar and optical tracking of artillery shells and aircraft, and to look at the state of the art remote control technology at the Sperry Gyroscope Company. He was astonished at what he found there.

As Pickering later explained in a paper presented to the International Academy of Astronautics in 1972: "It was important to recall that the focus of the prewar electronics industry was upon commercial broadcast and communications technology: television and feed back-controlled automation were on the bench, not on the shelf. High-frequency applications—such as radar was to be—were severely limited by the lack of an appropriate amplifying device. It was impossible to buy, and difficult to develop, equipment that would function reliably under the stresses of field operations or rocket flight. But wartime mobilization changed all that.

During this period the state of electronics technology advanced rapidly, almost violently. Anglo-American collaboration made possible a large and growing family of radar equipment and widened fields of application. Components rugged enough to ride an artillery shell, exemplified by the proximity fuse were in production. Aircraft auto pilots, low-noise communications, and fire control systems became widely available. Most of us realized how far the techniques had advanced only when in post-war surveys we observed the extent to which allied efforts had outstripped those of the Germans and Japanese. I later found, for example, that although the V.2 development rounds carried a radio telemetry system, the Peenemünde engineers had to rely principally upon tracking and recovering the wreckage for performance and diagnostic information."¹⁰

This was the wartime technological background against which Pickering began his association with the Jet Propulsion Laboratory in late 1944 as chief of JPL's remote control section.

Meanwhile, JPL forged ahead with the Private program. Test firings of the Private in December 1944 at a site called Leach Springs, deep in the Mohave Desert had reached an average range of 10.3 miles and provided the Laboratory with its first demonstrated success in rocket flight. However, later tests of a more advanced version of the Private that used wings to increase its lifting capability were largely unsuccessful. They did, however, demonstrate the essential need for a central guidance and control system for the successful flight of a guided missile, a fact that came as no surprise to either von Kármán or to William Pickering.

Early in 1945, about the time the ill-fated Private rockets were being prepared for test firing, the Army approved a JPL proposal to build a scaled-down version of the Corporal that could also be used as a high-altitude sounding rocket. Known as the WAC Corporal, it was to be propelled by a liquid fuel engine manufactured by Aerojet, enhanced by an additional solid fuel booster at launch to give it a launch speed of 400 feet per second. At that speed, the designers believed, gyro-stabilization was unnecessary, since deviation from the vertical would be minimal.¹¹ Ready to launch, WAC Corporal was 16 feet in height, 1 foot in diameter. The first flights in October 1945 at the newly constructed White Sands Proving Ground in New Mexico proved to be outright successes. Radar tracking showed that it reached an altitude of more than 40 miles, before returning to an impact point alarmingly close to its point of launch. Additional flights were equally successful.

Subsequently, the initial design was improved to reduce weight and to simplify construction, and a five-channel FM/FM telemetry system, based on Pickering designs and built by JPL's remote control section, was added. In addition, the improved version carried a parachute recovery system that could preserve the instrument package on impact, or even preserve the whole missile if necessary, undamaged.

The second set of WAC Corporal tests began in late November 1945 just as Pickering returned from a lengthy tour of post-war Germany and Japan. They took place at White Sands.



Standing tall: Frank Malina with the WAC Corporal in its launch stand at White Sands test range, New Mexico, November 1945 (Koppes: Romantic Rocketry) (Photo: NASA/JPL-Caltech Archives, Photo number P293-364).

For Pickering, these tests formed the beginning of a long and interesting association with the problems of test-range operations and flight instrumentation that would prove invaluable to his career in the years to come.

Speaking of the WAC Corporal he said: "It was a triumphant program in many respects. Outgrowing its research and development function it offered, for the first time, the realistic role of a scientific instrument carrier in a simple, relatively cheap form. It outperformed specifications, exceeding 200,000 ft altitude, a world record at the time. It brought forth a new design cycle for rocket engine and airframe. But most important here, its launch operations, involving the JPL crews, the Aberdeen [radar] tracking team and the White Sands missile range were a valuable preparation for the Corporal [missile] testing to come."

Ultimately, the WAC Corporal became the genesis of the Aerobee—a high altitude sounding rocket built by Aerojet for a program of high altitude research conducted by the Applied Physics Laboratory of Johns Hopkins University, in the 1950s.¹²

A Short, Cold Peace

In May 1945, shortly after the end of the war in Europe, von Kármán led a team of American scientists to Europe on a fact-finding tour of German scientific research facilities specifically related to aeronautics and the development of rocket propelled missiles, particularly the V-2. Von Kármán's group was sponsored by General Hap Arnold, with whom von Kármán had maintained a close working relationship throughout the war. It comprised a number of high-level military personnel that had interests in German military technology, as well as a number of prominent civilian scientists. Among others, von Kármán invited Malina and Pickering to join his group. Hostilities had barely finished when the group reached Paris to begin its tour.¹³

Pickering recollected some of the outstanding events from the tour: "von Kármán was invited up to a place in Denmark to witness the launching of a V-2 that was sponsored by the British group, and I went along with him. One of the constraints was that it [the launching] had to be far enough away so that whatever way it went, it would not get to England. It was a successful launching, and the first time any of us had seen a very large rocket launching. On the way [by aircraft] to the launch site, we stopped at an airfield near Hamburg and as we opened the door of the airplane we were greeted by an Honor guard all drawn up with rifles ready to 'Present Arms.' As we stood in the doorway von Kármán whispered to me, 'What do we do now?' So we walked stiffly down the steps, shook hands with the dignitaries, and we went about our business. We were all honorary Army Colonels and when we had dinner with them that night we learned that they were expecting General Montgomery and his staff, but ours was the first plane to land and so we received the honors."¹⁴

From Denmark the party visited other parts of Germany to talk to German scientists before moving on to Japan, which had by then surrendered to the allied powers. Von Kármán remained in Paris to complete his report on the group's findings in Europe for General Arnold.

"In Germany," he later reflected, "the aeronautics work was well organized, but the electronics work did not seem to be so well done. The Japanese seemed, for the most part, to be copying what was going on in the West, although they were beginning to develop some ideas of their own." In short, he found very little in Germany or Japan that could add to what JPL was already doing in the field of test instrumentation and electronics development.

In the short, cold peace that followed the conclusion of World War II, William and Muriel Pickering set about readjusting their lives to the new conditions that then surrounded them. By then, William was well on his way to becoming a full professor on the faculty at Caltech and his future in academe seemed assured. Although he could have joined the JPL organization on a full-time basis at any time, he regarded the work there as a research project for the Army that would terminate when the research work was completed and the final reports delivered, and he did not intend to relinquish his chosen career in teaching and research at Caltech for a short-term interest such as that.

Family life for the Pickerings had changed early in the war when son Balfour joined the family in 1939, and daughter Anne Elizabeth arrived in 1943. The family lived in a small house on Craig Avenue in Pasadena during the war. It was a quiet middle-class neighborhood close to Caltech and downtown Pasadena and, when it was time, the children could go to the nearby school. It was a small, but happy and convenient arrangement. However, in 1948, when William's father Bert came over from New Zealand to visit, they decided they needed a larger house to raise their growing children and moved to a beautiful Spanish-style house in Altadena, an upper middle-class area in the lower foothills of the San Gabriel Mountains overlooking Pasadena. The house was large and the children soon made good friends in the neighborhood.¹⁶ There, in 1948, in the quiet, wooded foothill city of Altadena, the Pickerings settled in to raise their family and to establish a professional career in what turned out to be the short-lived peace that followed the end of the "hot war."¹⁷

Guided Missiles

Things changed at JPL in 1946 when Malina resigned and Caltech appointed another member of its faculty, Louis Dunn, to replace him as director. In keeping with Dunn's personality, maturity, and experience, the organization became more formalized and, as a portent of things to come, JPL's strong relationship with Caltech began to weaken. JPL began to develop a strong sense of autonomy that would color its institutional image for years to come.

The Army exercised minimal supervision of JPL's activities, and the annual review of JPL's progress, and subsequent renewal of the contract, became almost a mere formality. Invariably, the Army approved JPL's funding request for the following year.¹⁸ It followed, of course, that Caltech always received a proportionate share of the contract award to JPL in the form of a management fee that varied from year to year, but was approximately 10 percent. This mutually beneficial arrangement eventually strained the business relationship between Caltech and NASA.¹⁹

Pickering continued to teach his advanced electrical engineering classes and supervise some graduate students at Caltech until about 1951 or 1952, although this work gradually tapered off as he became more involved with the ORD/CIT contract at JPL. Fully engaged with his advanced engineering classes and graduate students at Caltech, and increasingly involved in the fascinating electronics-related problems at JPL, Pickering paid little attention to the institutional stresses that were developing between the two organizations of which he was an integral part. Confident of a secure future as a tenured faculty member at Caltech, he felt that he could live with the conditions that aggravated so many of his colleagues at both JPL and Caltech.

Despite his part-time status at JPL, he enjoyed considerable authority at the Lab. He hired the best engineering talent he could find to staff the remote control section. He brought in people like Lehan, Cummings, Rehtin, and Parks, former graduate students of his from the early 1940s, to work on the challenging new problems that faced JPL. In the electronics area, Dunn's people did the work at JPL while he provided the direction needed to keep the electronics effort moving forward.²⁰

While the main thrust of JPL's effort had been concentrated on Private, planning for the second phase of the ORD/CIT program, the Corporal, had proceeded apace and was well advanced when Pickering returned from his tour with von Kármán.

The Corporal design represented a major technical advance from the Private series in many areas: rocket engine design, aerodynamics and flight path determination, airframe structure, and—most significantly—telemetry and guidance, the two areas for which Pickering was personally responsible, and in which he was rapidly acquiring a prominent national reputation. Telemetry was becoming an essential tool for rocket research and testing.

By that time, Pickering's group had built, and flight-tested, several telemetry systems for use on rocket airfoil test (RAFT) vehicles that had been fired on the Mohave Desert site for aerodynamic research purposes early in 1945. Based on his original cosmic-ray work with the high-altitude balloons, these systems employed three-channel or five-channel FM/FM analog data transmission techniques. They had also been fitted to the later WAC Corporals where they proved very effective in returning the in-flight data. These tests had given the group valuable experience in field operations and telemetry data acquisition. Obviously, these units could easily be adapted for the Corporal flights.²¹

Pickering clearly saw that, to meet its target accuracy goal, Corporal would also have to incorporate what he called a guidance system. Simply shutting down the rocket motor after a fixed interval of time after launch and allowing the missile to coast on a ballistic trajectory to its target, as did the V-2s, would not be good enough for Corporal. With Corporal, its designers were trying to drop a missile into a 1000-ft diameter circle at a distance of 75 miles to 150 miles from its launch point. It was somewhat like trying to thread a needle from a city block away. A specification like that called for a completely new approach to controlling the path of missiles in flight.

As part of his function at JPL, Pickering had been thinking about this problem for some time and had set out his ideas in a technical paper early in 1945.²²

Pickering's paper was conceptual in nature. It was the task of Malina's engineers at JPL to turn these conceptual ideas into electrical hardware that could be integrated into the overall aerodynamic and propulsion system of the Corporal research test vehicle, and evaluated under real flight conditions at the White Sands test range. Although the initial radio guidance system for Corporal was very rudimentary, it contained all the basic elements required to demonstrate the principles involved in missile guidance. At this stage it was a research vehicle not a weapon system, and understanding the basic principles was the prime objective.

The system envisaged for the first Corporal research test vehicle was similar to that used for aircraft autopilots. Gyroscopes carried within the missile established appropriate flight references for roll, pitch, and yaw. In-flight deviations from these references were corrected by four servo-driven control surfaces, or fins, at the rear of the vehicle. During flight, a ground-based operator kept the missile within the limits of a predetermined trajectory by transmitting to the missile suitable commands for adjusting the reference positions. The operator's job was to guide the missile to the rocket motor cut-off point. After that point the missile would pursue a very precise, free-fall parabolic trajectory to the desired impact point, much like an artillery shell.

Pickering's design included an analog, FM/FM telemetry system to measure the missile response to movements of the control surfaces, fin positions, and aerodynamic loads, and it used the radar beam to not only track the missile, but also to convey the operator-derived control signals to the internal missile guidance system.

Finally, Pickering included a qualifier. He pointed out that this proposal made no provision for controlling the missile velocity. "There is no doubt that," he said, "as shown by the German experience, such control is necessary to attain accuracy without using external control near the target. Accuracy however is not one of the prime objectives of this model, and the complication introduced by velocity control does not warrant an attempt to use it at this time."²³ But accuracy would soon become a prime objective and when it did, Pickering would be ready to deal with it.

Pickering's team at JPL soon turned these concepts into reality. Using special bench-tested components and integrated test assemblies, a complete control system was constructed and tested at the Lab. Of necessity, they used existing gyros and other components that could be adapted for the purpose. In those early days the components required for missiles and rockets were available only "off-the-bench, not off-the-shelf," as Pickering put it. Two years later, the first of the Corporals to carry a simple guidance system, designated the "E" version, was ready for in-flight testing.

Pickering described the first two attempts at guided missile flight in his memoir: "On 22 May 1947, Corporal E, No. 1 rose from White Sands. Weighing almost six tons and stabilized by a pneumatic Sperry autopilot, the slim white rocket lifted off its launch stand, gradually pitched forward toward the target and flew [followed] a ballistic curve to within two miles of its target [at a 62-mile] range.

No precision guidance had been employed, although an experimental radio command was exercised successfully. A ten channel FM-FM telemetry set (actually two of the WAC telemetry sets) returned measurements of guidance and propulsion system parameters, and the trajectory was plotted from radar position and velocity measurements acquired from an active [flight transponder] tracking system."²⁴

The JPL launch team at White Sands, led by Dunn and Pickering, celebrated their success with a wild party that night at the military base headquarters. Pickering continued: "Buoyed by this success we prepared the next bird for launching eight weeks later. The second Corporal flight was a fiasco. Apparently the air-pressure regulator which controlled the flow of propellants to the rocket engine malfunctioned; the engine ignited but with insufficient thrust, and burned on the stand for 90 seconds before the rocket was light enough to get off the ground. Then the missile rose, tipped over, headed for the sand and proceeded to skitter through the desert underbrush under power until it blew up. A wag at the scene named it the 'rabbit killer'."²⁵

Although the next several flights were only partially successful for various technical reasons, the telemetry system provided excellent records for subsequent engineering analysis of the in-flight problems, many of which were attributed to the damaging effect of the high vibration environment on the mechanically-sensitive electronics components of the guidance system. On the final test in the series, the team was denied even that meager satisfaction when the range safety officer was forced to destroy the missile in flight to prevent it hitting a nearby township. The total failure of Pickering's guidance system shortly after lift-off had allowed the fully powered-up missile to wander, mindless and uncontrollable, beyond the safety limits of the test range.

Somewhat disappointed, but much the wiser for their first experience with missile guidance systems, the team returned to Pasadena to analyze the telemetric, radar, and photographic data and plan the next steps in the Corporal

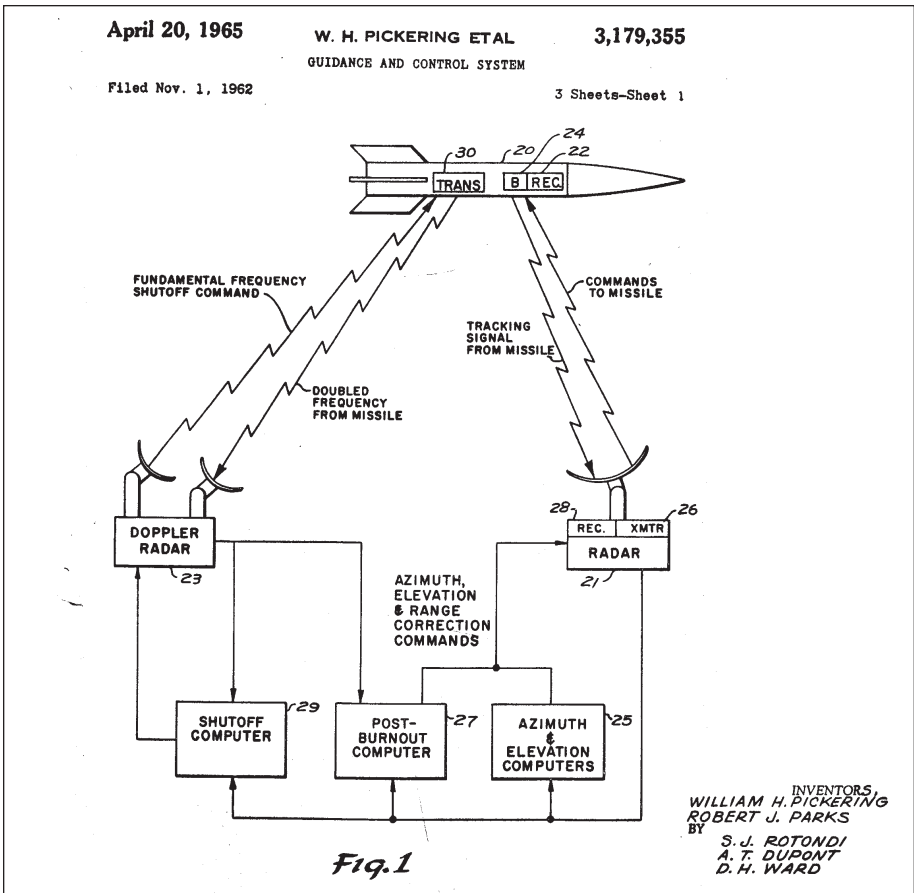

The basic concept of a guidance and control system for the Corporal missile due to William H. Pickering and Robert J. Parks. It employed an SCR-584 radar beam-riding guidance system with a separate Doppler velocity measurement system to cut off the rocket motor at a prescribed point on the trajectory. United States Patent 3,179,355 was issued to Pickering and Parks as Inventors in April 1965 (William H. Pickering: personal papers) (Photo: Courtesy of Pickering Family Trust).

guidance program. For the next couple of years the engineers at JPL redesigned, built, and tested various elements of the guidance system including the ground radar to improve its in-flight performance, resistance to vibration, and reliability.

During these initial flights, Pickering had been very much aware of the shortcomings of his original design. As he pointed out in his proposal, it made no provision for measuring the missile velocity, a critical factor in the ultimate accuracy of the overall guidance system. Working on this problem with Robert Parks, a former graduate student that he had hired into JPL, he had

developed an idea to correct that deficiency by making use of the “Doppler effect,” or change in frequency of a radio signal transmitted from the missile as it receded rapidly from the launch site after firing. A special Doppler radar would be used to send a precisely known radio signal up to the “bird” during flight. The bird would retransmit the uplinked signal back to the ground where the radar receiver would compare the received signal with the transmitted signal to extract the difference in frequency due to the receding motion of the bird. The so-called Doppler frequency would give him a direct measure of the velocity of the “bird.” The basic idea is illustrated in the diagram

In the improved version of the Corporal guidance system, this critical “velocity” parameter would be provided by the Doppler radar.²⁶

While his group at JPL worked on improving the Corporal guidance system, Pickering continued his academic work at Caltech and also devoted some of his attention to the matter of optical and electronic instrumentation facilities for flight testing long-range missiles. Earlier, he had played a major role in setting up the electronic instrumentation, radar, and telemetry for the test range at White Sands. In fact, JPL's WAC Corporal firings had inaugurated the new facility as its first paying customer back in 1945. He had accumulated a great deal of experience in the instrumentation and operational complexities of rocket testing. When the U.S. Navy began to set up a Naval Air Missile Test Center (NAMTC) at Point Mugu, near Oxnard, California, it turned to JPL for advice and consultation and Pickering directed several studies to help the Navy set up an instrumentation system to suit its purpose there.²⁷

As if this was not enough, Pickering also served as chairman on a committee sponsored by the Research and Development Board of the Department of Defense (DOD) to establish and coordinate standards for telemetering systems the military test ranges then being constructed throughout the country. At the time, Pickering's analog FM/FM telemetry system, which had a proven record of performance, was selected as an interim standard pending the development of a pulse, or digital, system. As the military needs for in-flight missile testing expanded, test range instrumentation became complex and the committee assumed a broader role as the Inter Range Instrumentation Group (IRIG). The IRIG standards, adjusted to accommodate new developments in digital techniques, formed the basis for all telemetry systems for DOD missile ranges in the U.S. far into the future.²⁸

By 1949, William Pickering, then age 39, had become a very busy young man. Engaged with Corporal guidance problems at JPL, his graduate students at Caltech, instrumentation systems for military test ranges and JPL's wind tunnels, and driven by a persistent interest in the distant potential of rockets for high-altitude research; he nevertheless enjoyed watching the progress of his rapidly maturing family. His widowed father, Bert, had by then returned to New Zealand to live out the remainder of his life with cousins in Auckland.

His children were growing up fast and doing well at school and, as time permitted, Muriel began to develop associations with women's groups at Caltech and Throop Memorial Universalist Church and to become involved with the local community affairs, particularly those relating to the local library.

As the communist threat to America's security began to loom larger on the international horizon, Army Ordnance began to focus more intently on the results of its rocket research program at JPL. In the five years since its inception, the Corporal guided-missile research project had shown great promise. Four test flights had been carried out, one of them highly successful, and valuable performance data had been obtained from the others. JPL believed that it now understood the fundamental problems of propulsion and guidance as they related to guided-missile technology. In mid-1949, with all of this in mind, Colonel (later Major-General) Toftoy of the Missiles and Rocket Branch, U.S. Army Department of Ordnance, approached the director of JPL with a serious and far-reaching question: "Would it be feasible," he asked Louis Dunn, "to convert the research-oriented Corporal test-vehicle into a military weapon system capable of carrying a warhead with great accuracy to a specified target, and capable of operation under field-combat conditions by suitably-trained service personnel?"

It was a question that provided much food for thought indeed, and Dunn took it upon himself to provide an answer. He called on his colleague Bill Pickering for help.

With typical brevity of statement, Pickering recalled the decision-making process, "Dunn brought me into the inquiry and we gave the matter much thought before deciding in effect, 'Let's give it a go'."²⁹

In September 1949, Dunn and Pickering made the long train trip to Washington, DC, to confer with Colonel Toftoy at the Pentagon. It was a very unpretentious meeting, just four of them, two military officers and two scientists around a table in a small Pentagon office. Toftoy described the Army's need for a demonstrably field-worthy guided missile, while Dunn and Pickering tried to explain what they thought they would have to do with the existing Corporal design to make it so. Both men were impressed by Toftoy's confidence in JPL's ability to undertake what was essentially an industrial-development task considering that JPL was a research-oriented organization and had no experience in that field. "We were being pretty naïve about it [the complexities]," Pickering recalled, "but they [the Army] didn't really understand the complications either. They were sufficiently impressed by our record that they believed it would go all right. I believed we could handle the guidance problems and Louis was confident that we could handle the industrial-engineering transition. It really was as simple as that; we said we could do it, and Toftoy said, 'Go ahead'."³⁰

Led by Louis Dunn and William Pickering, JPL was about to become involved in its first guided weapon development program for the U.S. Army.

When they returned to Pasadena, Dunn asked Pickering to phase out his academic work at Caltech and to take charge of the Corporal weapon development as a full-time project manager. Pickering agreed, and few months later, the program was underway.

Pickering's moral view of the work that he was undertaking, at the time, is reflected in the following conversation with the author:

DJM: Did you (as a professed man of science) have any moral scruples about the end use of the wonderful technical device (Corporal) that you were developing?

WHP: Oh yes, I did, from time to time, because we knew that the Corporal as a weapon was being thought of by the Army as a means of carrying an atom bomb. The whole idea of that was an unpleasant thing to think about in detail for me. On the other hand, the satisfaction of being able to oversee the technical design and solve the technical problems that enabled you to throw a missile on a target one hundred miles away was pretty challenging and very satisfying when you showed you could do it.

But I thought of myself as contributing in a minor way as far as the total picture was concerned. We were not making the ICBMs (intercontinental ballistic missiles) that were aimed at destroying cities. We were building a device that would be a superior weapon on a battlefield.

DJM: You perceived that the technical challenge was sufficient reason to be involved and you did not concern yourself about the ultimate end result. There were others whose job it was to worry about that.

WHP: That's true. The people who were doing the planning and application to particular situations were the one who should worry about that.

You have to put the whole thing against the background of Cold War development. We knew that the Soviets were developing an ICBM, and you might ask did the personnel at the Lab as a whole worry about these issues and was there any discussion about moral problems? I do not remember any such discussions. I think that they simply accepted it as an interesting technical job, with a lot of interesting features, and got on with it.³¹

When Pickering began work on the "weaponization" of the Corporal, the propulsion and aerodynamics systems were quite advanced. Both he and Dunn believed that all that was needed in those areas was refinement, or optimization, of already demonstrated systems and hardware. These were largely matters of weight, material, and dimension; although the most critical technical problem,

that of long-range accuracy, remained a significant problem in Pickering's mind. Subsequent events, however, were to prove them wrong.

Problems in manufacturing components for the Corporal missiles to meet the required standards of reliability proved to be more complex than they anticipated and forced the introduction of strict new controls into the manufacturing processes. In due course, the quality of the completed missiles improved to the point where, by August 1952, Pickering was ready to give approval the start of test firings of the contractor-built Corporals at the White Sands test range.

Pickering had been associated with the White Sands missile range since the early WAC Corporal firings in 1945. Although it was essentially a military establishment, he and his JPL team of civilian scientists and engineers were highly regarded, not only for their highly-advanced technical expertise but also for their very "laid-back" social attributes. Under the direction of their leader Bill Pickering, they manifested their awesome technical prowess on the test range by day, and their equally awesome social attributes on the military base and in the nearby towns of Las Cruces and El Paso by night. Also their presence was frequently in evidence between the U.S. and Mexico, in the Mexican border town of Juarez.

Pickering was no stranger to field testing. He believed strongly in its worth, and he had an imposing record of cosmic ray work with Millikan, under extreme duress at times, to show for it. All engineers, he insisted, should be prepared to demonstrate, personally, the efficacy of their designs in the field. It was not a responsibility that could be delegated. Besides, the shared experience of intense and at times stressful experience of away-from-home test trials forged a common bond of dependence and trust and confidence among the members of the technical teams that were involved. The abiding nature of these relationships would carry many of the White Sands test teams far into the future fortunes of JPL.

Pickering enjoyed recounting a story related to this period of his life that concerned the introduction of air brakes for missile aerodynamic control.

It was easy to accelerate a rocket but how do you slow it down? At JPL, we had been debating that question for some time. One night, four of us were driving back from Las Cruces after dinner where we had been discussing that problem when suddenly, one of the aerodynamic engineers in the car said he had a great idea that he would demonstrate to us. When the car came to the top of the next hill, he told the driver to switch off the engine and coast full speed down the hill. When the car was really going fast, two of us pushed the two rear doors open against the rushing wind, and the car almost came to a stop. It was a practical and powerful demonstration of the efficacy of drag brakes at high speed that we used in later designs for Sergeant.³²

It was against this background that JPL began test firing the first of the contractor-built Corporals in August 1952. It was Pickering's project and he led the way. With Parks and Rehtin managing those sections related to the guidance and telemetry, areas for which his JPL division was responsible, he was able to take a broad overall interest in the missile and its performance. And what he found was not very good.

JPL's highly skilled and experienced crews fired 56 production missiles in that first year of test firings at White Sands. However, only 43 percent were considered successful, a value that fell far short of the 95 percent success rate required by the military specifications. Furthermore, production capacity had fallen far short of the goal of 20 missiles per month desired by the Army. A mere 13 missiles was the best run the contractor ever produced in any single month.

Matters became further complicated when JPL began training Army troops to prepare and launch the missiles. This training task went far beyond anything the lab had experienced before. It was even more foreign to JPL expertise than industrial production, and JPL did not do well. Dunn and Pickering were becoming engaged in a task that, essential though it was, held no challenge, interest, or attraction for either of them.

By mid-1954, the project had become a mess and an impasse loomed ahead. To head off a crisis and attempt to improve working relationships and communications between the three organizations, the Army appointed a technical committee led by JPL to coordinate the overall activities and resolve mutual problems expeditiously.

The work went ahead and eventually troop training improved, but the success rate of Army-directed test firings at White Sands rate fell far short of Army expectations, and the usefulness of the Corporal system as an effective military weapon came under serious question. As Pickering and Dunn had made clear at the outset, the missile contained many other shortcomings that were a consequence of its nonmilitary origins and such problems could not be corrected by any amount of redesign.

The Army, however, had no option. Pressured by the tense international situation in Korea and Europe that engulfed the nation in the mid-1950s, it went ahead and, a year later, deployed the Corporal as a surface-to-surface guided ballistic missile in Europe. Thus, Pickering's Corporal project produced the first guided missile of that type to see operational use for the U.S. in the Cold War era. Despite its shortcomings, it was an awesome weapon when tipped with an atomic warhead, although it may well have been more effective for its psychological value as a deterrent rather than its tactical value as a weapon.

Fully engaged with the exigencies of the Corporal program in mid-1954, Pickering was taken completely by surprise when, quite suddenly, Louis Dunn resigned from JPL to join a newly-formed missile engineering company in Los Angeles that was engaged in building Atlas, the United States' first intercontinental ballistic missile. When Caltech president Lee DuBridge

asked Dunn to suggest a replacement for his position, Dunn, equally unexpectedly, nominated Pickering. Although DuBridge knew that Pickering's field of expertise lay in missile guidance, telemetry, and electronics, Dunn convinced him that Pickering was at once "the right man in the right place at the right time." President DuBridge called Pickering over to the campus for a chat.

Recalling that afternoon meeting many years later, Pickering said:

I was surprised when he called me, quite frankly, because my thinking of the Laboratory was that it was still primarily aeronautics and chemistry and mechanical engineering with electronics just tacked on. And so the idea that I, as an 'electronicker,' would be offered the job did not occur to me. But, I had no hesitancy in deciding [to accept]. I had been with the Lab long enough to know what was going on and how things were done up there. I was definitely very happy to take it on. DuBridge asked me if I would treat it as a stepping stone to some big industrial job in the sense that Louis Dunn did, and I assured him that I would not, and that I wanted to come back and resume my job as a Professor. He said, 'OK I will give you leave of absence'.

Wanting to "come back as a professor" was a reflection of Pickering's view of the JPL situation at the time. He knew he would not be happy just making a succession of weapons for Army Ordnance. Up at JPL they were working on the Corporal, and studies for the follow-on Sergeant were well advanced. He felt obligated to see that work completed, but did not want to do another one [weapon]. "It was a sort of qualified answer," he said, "[Rather like] I would take it for the time being." DuBridge agreed, and gave him leave of absence from Caltech—for more than 20 years as it turned out—but no one foresaw that happening then.

In pensive mood, Pickering drove back home to Altadena for a quiet celebration with his family. Unaware of the onerous responsibility that he had just assumed, the family knew only that he had "got a big new job" and they were happy for him.

Everything changed for Pickering after that. No longer a college professor working in a narrow field of interest of his own choosing, he now had to step back and take a much broader view of the Laboratory's activities. By that time the population of the lab exceeded 1,000, and its annual budget was more than 11 million dollars. With its Army contracts as the dominant activity JPL had become a significant organization in its own right. Robert Parks took over Pickering's position as project manager for Corporal, while Pickering addressed organizational matters and began to make his presence felt as an administrator.

Koppes aptly described the new regime: "More personable and less of a martinet than Dunn, Pickering was also less rigorous as an administrator. . . . Some interpreted Pickering's *laissez-faire* attitude toward management as indecisiveness. . . ." Nevertheless, the transition to the new director was smooth, relations with the Army and the Corporal contractors were improving and



JPL Director William Pickering at the firing console for the launch of Corporal round 100, at White Sands missile range, April 1955 (Photo: NASA/JPL-Caltech Archives, Photo number P19445B).

just ahead lay a tantalizing new challenge for JPL, a follow-on contract for the guided missile weapon system, Sergeant.

While Pickering settled into the director's office at JPL, test firings of the Corporal continued at an ever-increasing pace at White Sands. When the test program was finished in 1955, they had launched over 100 Corporal missiles.

Although he was no longer directly involved in the test firings, Pickering exercised his prerogative as director by electing to press the firing button for Corporal round 100. Corporal round 100 was set up on its launcher and programmed for an impact point due north of the launch area. The weather was perfect, photographers were on hand, and the countdown proceeded smoothly to the last few tense seconds. Five, four, three, two, one: FIRE. Confidently, the new director pressed the red button on the firing panel. The 40-ft long, slender, white missile rose majestically straight toward the heavens and began a graceful turn towards . . . not the north as programmed but, to the east, and ignominious destruction by the range safety officer. Said Pickering with a twinkle in his eye, "They never let me fire a Corporal again, even if I was the Director."³³

Shortly before Pickering took office, a special Ordnance-based committee evaluated proposals from three study teams, including JPL, for a follow-on to the Corporal. Based on the committee's recommendation, the Army accepted JPL's proposal and issued a new contract to that effect in late 1954. The new weapon system would use a solid-fuel propulsion system to avoid the cum-

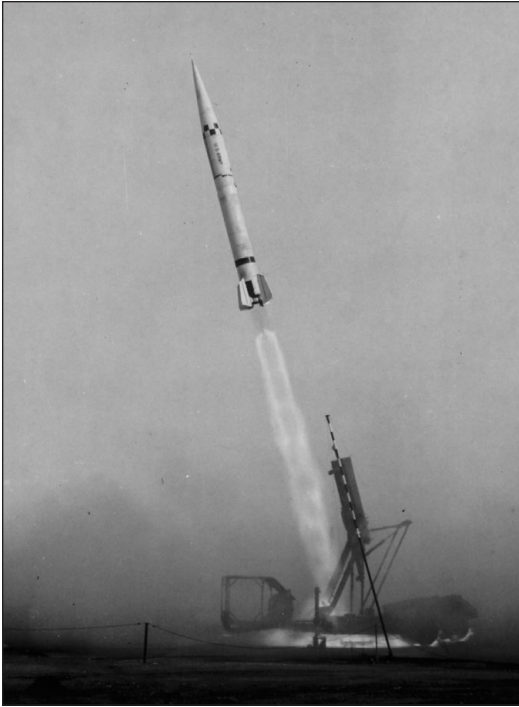

Sergeant, an inertially guided, solid-propellant, surface-to-surface, ballistic missile launches from White Sands missile range in the course of JPL's four-year development and production program for the U.S. Army, 1956-1960 (Photo: NASA/JPL-Caltech Archives, Photo number 293-3302B).

bersome ground support systems required by Corporal, it would use an improved radio-inertial guidance system to avoid interference from enemy counter-measures, and range and accuracy would be improved. It would be designed, from the start, as a complete weapon system. The Sergeant weapons system, including troops trained in its field operation, was to be ready for service by 1960.³⁴

Determined to pass on all of the experience they had accumulated on the Corporal pro-

gram, Pickering appointed Robert J. Parks, long time colleague and chief of the JPL's guidance research division, as project manager for Sergeant. Under Parks's direction, the ground-to-air radio links were simplified, transistorized electronics and new packaging was implemented to reduce vibration, and automatic checkout equipment sped up launch readiness procedures. Fitted with aerodynamic drag brakes to reduce the missile velocity to the desired value, and inertial guidance system, Sergeant met or exceeded its targeting accuracy goals and provided a high measure of freedom from enemy radio interference.³⁵

Said Pickering:

The Sergeant missile development went forward at a more rapid pace than Corporal, partly because of the simplicity and excellent performance of its power plant, but mostly because both engineers and soldiers were building on the Corporal experience. Less than three-dozen Sergeant missiles were test flown at White Sands, compared to over one hundred Corporals. . . . Corporal had taught us how best to use industrial collaboration. The engineering firm that would build the Sergeant, a new division of the old Sperry Gyroscope Company that I had visited on my first trip out of JPL a decade before, joined [JPL] as cocontractor during Sergeant's development.³⁶

Speaking of the apparent contradiction between his Laboratory's engagement with missile development and its primary mission of applied science, Pickering observed: "the ultimate positive effect of missile development on applied science was almost a case of serendipity rather than technological determinism—the missile contributed much of the technology for, as well as the impulse toward, the practical science of astronautics."

When he took over as director these intertwining streams of activity, missile development, and applied technology coalesced into a broad stream of endeavor that began to carry the Laboratory forward, with increasing speed, toward space.

Toward Space

Pickering's interest in upper-atmosphere research went back a long way.³⁷ Ever since 1946, when he returned from the post-war tour of Germany with von Kármán, he had been involved in the ultimate destiny of the V-2 rockets that had been brought to the U.S. from Europe, and the German "rocket scientists" that accompanied them. In this country, the V-2 program was directed by the Army Ballistic Missile Agency (ABMA) and managed by the Army's Redstone Arsenal in Huntsville, Alabama. When Army personnel, assisted by the German engineers then assigned to the staff at Huntsville, began test-firing the V-2's at White Sands late in 1946, a group of American scientists, including Pickering, were quick to seize the opportunity to substitute a science payload for the missile's warhead to gain reliable and virtually cost-free access to the upper atmosphere and the regions beyond. The Pickering-designed telemetry system was easily adapted to provide a data return channel for the upper atmosphere science measurements. Working with this program at White Sands, Pickering inevitably made the acquaintance of the German experts including von Braun and James Van Allen, an eminent scientist from the University of Iowa. So began a lifelong association that would bring worldwide, public acclaim to all three men in the years ahead. A new era in the field of upper-atmosphere research was about to open and Pickering, Van Allen, and von Braun were at the forefront.

Although rockets appeared to be attractive vehicles for high altitude research, they had a serious deficiency for cosmic ray investigations due to the short duration of their flight above the atmosphere. Pickering recognized the problem in a 1947 paper when he suggested that: ". . . extensive cosmic-radiation studies be deferred until a satellite rocket can be produced."³⁸ He did not predict when that might become possible. Nevertheless, he sustained his interest in the subject and became a strong advocate for a rocket-propelled scientific satellite when the necessary technology became available.

When the National Academy of Sciences established a committee to consider options for the United States' participation in the International

Geophysical Year (IGY),³⁹ Pickering joined a subcommittee of the rocketry panel. It became known as the long playing rocket study group, so named after the latest device for playing long-duration audio recordings that had just come on the market. In this group, he and others “reported on the usefulness of a satellite in the IGY program without advocating any specific project.” In October 1955, when the IGY committee organized a technical panel for the Earth satellite program, Pickering became a member and, throughout the life of the IGY, headed a working group on tracking and computation of satellite orbits.

Project Orbiter

In mid-1954 Pickering took part in a symposium to discuss the potential for building and launching an Earth satellite as part of the United States’ contribution to the IGY. Engineers and scientists from the Office of Naval Research, the American Rocket Society, the astrophysics community, and the Army Ordnance Rocket Program, including von Braun, attended. Discussion was vigorous and there was no lack of ideas. Influenced no doubt by Pickering and von Braun, the outcome of the proceedings led to a proposal to put a lightweight, inactive satellite into Earth orbit using a Redstone missile as a first stage, with a cluster of JPL-developed solid rockets as the upper stage.⁴⁰ It was an innovative idea that made use of existing technology from ABMA and JPL to create an entirely new device that pushed upper atmosphere science beyond anything formerly possible. The proposal was called Project Orbiter. Calculations showed that the idea was entirely feasible and, for the next year, Project Orbiter was the subject of much study and debate. After considering its options, JPL decided that its well-tested 1/5 scale motors from the Sergeant program would be most suitable for the Orbiter upper stages. Studies showed that, using the Redstone and scaled-down Sergeant motors, both flight-proven hardware then available, the Project Orbiter in this form could be launched by August 1957, just a few weeks after the planned opening of the IGY observations period. It was submitted to the IGY committee for consideration as a joint ABMA-JPL proposal.

Along with the ABMA-JPL proposal, the IGY groups, including Pickering’s technical panel, evaluated a competing proposal called Project Vanguard that had come from the Naval Research Laboratory. Unlike the Orbiter, Vanguard used a non-military rocket to carry a small science package into Earth orbit and was provided with a radio tracking system. Although the Vanguard rocket had yet to be proven in test firings, its nonmilitary origin was perceived as a favorable feature in the context of the times, and the science package and radio tracking system were seen as additional advantages over the Orbiter proposal. Realizing the comparative shortcomings of the Orbiter proposal, Pickering’s team scrambled to adapt their existing telemetry and radio guidance technology for use with Orbiter. Although this effort produced an effective, ground-

based tracking system known at JPL as Microlock, the effort was to no avail. President Eisenhower had previously expressed a strong desire to keep the nation's scientific satellite experiments out of the military domain, and the DOD committee responsible for making the ultimate decision ruled in favor of the Vanguard proposal for America's first Earth satellite program.

The Orbiter proposal was shelved and Pickering, despite his disappointment at the committee's decision, turned his attention to “. . . organizing the operational support for the Vanguard mission. It was part of our (the IGY working group) task to encourage and coordinate various efforts, including international activities, in connection with the observation and tracking stations for Vanguard.”⁴¹

Project Vanguard

As part of the United States' contribution to the IGY, Project Vanguard was not encumbered by the security constraints that covered all of Pickering's work for the military establishment. Pickering was quick to take advantage of that fact to promote his ideas for Earth satellites. With this as his principal topic, his remarkable propensity for public speaking soon manifested itself in an ever-increasing number of speeches and lectures in the public sector. It began in Los Angeles in October 1956 with an address on Project Vanguard to a group from the motion picture industry. In the light of events that would follow just one year later, this speech became a landmark event in the sense that it marked Pickering's first public statement of the United States' intent, and capability, to put a satellite into orbit about Earth for purely scientific purposes. His speech was titled “Project Vanguard: The Earth Satellite Program.”⁴²

He began with a description of the IGY program that confirmed the United States' intent to launch an Earth satellite the following year.

The earth satellite program of the United States is part of the International Geophysical Year Program. During the period from July, 1957 to December, 1958, there will be a concerted effort on the part of most of the nations of the earth to gather data of geophysical interest. . . . The international committee which is coordinating the IGY program . . . recommended in October of 1954, that a satellite program would be of extreme value as part of the IGY activity. In July of last year, the President announced that the United States would indeed fly a satellite as part of our contribution to the IGY program. Since then, the Russians have announced that they also will fly a satellite. The President has stated that each of the services will contribute to the effort, but the primary responsibility has been given to the Navy. The Naval Research Laboratory has set up what is now known as Project Vanguard.⁴³

In his typical tutorial style, Pickering continued with a most lucid, but quite technical, description of the physical principles underlying Earth-orbital flight, the rationale for firing the booster rocket in an easterly direction to take advantage of the rotation of Earth, and the way in which small variations in the satellite's launching direction affect the shape of its ultimate orbit, and its inclination to Earth's equator. "So to sum up," he said, "we must take our satellite object to an altitude of 300 miles and launch it with a velocity of five miles per second in a specific direction with an accuracy of about one degree." To his audience, Pickering might have conveyed the impression that "that was all there was to it. Putting a satellite in orbit was quite straight forward, just a matter of getting the numbers right." But no one knew better than Pickering that was not the case. It was an incredibly difficult matter, as events would soon show.

Concluding, he said, "The earth satellite program has stirred the imagination of scientists and the public alike. It will be a spectacular demonstration of the potentialities of modern technology and the first real step towards the conquest of space."

It was a masterful presentation that covered all aspects of satellite flight, at a level that did not condescend to the understanding of his listeners and yet held their interest and rewarded them with a fascinating view of the future of spaceflight. His ability to "hit the right level" and his articulate and compelling delivery would become the hallmark of Pickering's public speeches from this point on.

In February the following year (1957), he presented a seminar on "Some Problems Associated with a Small Earth Satellite" to graduate students at Caltech.⁴⁴ Relaxed, and obviously enjoying his return to campus as a lecturer, he used only a few handwritten notes to cover the complex mathematical principles involved and the practical engineering specifics required to realize the world's first spaceflight.

A few weeks later he addressed the graduating students of a small technical university in Los Angeles on the topic of "The Engineer and the Next Ten Years."⁴⁵ In this speech he emphasized vistas of endeavor and moral obligation that reached beyond the more traditional confines and physical limitations of the engineering profession.

As his public appearances began to attract attention in the area, an increasing number of invitations and requests for presentations to professional societies and educational institutions began to arrive at the JPL director's office.

In April 1957 he presented the annual Faraday lecture to the graduating students of a local high school.⁴⁶ For this speech he returned to the topic Project Vanguard with several important additions, which he went to considerable pains to explain. These represented the products of his IGY working group on tracking and orbit computation. They involved the "Moonwatch" network of optical telescopes to be established by the Smithsonian Astrophysical Observatory, the "Minitrack" network of radio tracking stations being set up by the Naval

Research Laboratory, and the informal amateur radio community that was being encouraged to listen for the satellite signal and send in reports. Between them, these groups formed a dense, worldwide set of observing stations whose reports would be used to calculate a very precise orbit for Vanguard.

After again describing the inherent scientific knowledge that could be deduced from a precisely-known orbit, Pickering speculated on the future of space research.

He said:

Before the end of the IGY, I believe we will see both United States and Russian satellites flying around the Earth, collecting data from outer space, sending us information on the conditions they observe, and providing us with a new type of astronomical object and a new geodetic tool for measuring the Earth. It might even be possible to send up some simple television devices and look at the heavens from a completely new viewpoint. Perhaps the astronomer's dream of a telescope outside the Earth's atmosphere can be fulfilled. It is quite certain that bigger and better satellites will follow the simple IGY devices. Probably both Russia and the United States, and possibly some other countries will build them. When we succeed with satellites of this size it will be relatively easy to send a smaller object on a longer trip through space—perhaps to circle the Moon.

In the light of later events it was a remarkably prescient view of the future, emphasizing the immediate utilization of space for scientific purposes and suggesting the further possibility of manned spaceflight.

Traveling Man

Bill Pickering had always been an avid traveler. He loved to see new places, meet new people; he was always “on the go,” making “deals,” and engaging in arguments where he advocated ideas for an Earth satellite program, or promoted JPL's interests and protected his control over it. The constant flux and pressures of life on the move seemed to provide a stimulus for his enthusiasm and an outlet for his inexhaustible energy. Elevation to the position of director increased, rather than diminished, his need to travel. Pasadena to White Sands, Huntsville, and Washington became a regular commute. He recollected “red-eye flights out of Los Angeles at 11:00 p.m. to Washington, DC, a day full of meetings and presentations at the Pentagon and a 5:00 p.m. return flight to Los Angeles. Muriel did not complain, but she clearly was not happy about it.”⁴⁷

It was all classified work and his wife could not know what he was doing. She perceived that he was away from home most of the time and accepted that

it was not conducive to any significant social life. She graciously managed the major tasks of dealing with the needs of the rapidly growing children, and she sought avenues of interest to satisfy her own intellectual talents. In later years, Beth Pickering Mezitt remembered her mother's public and private interests:

Not only was she active in the League of Women Voters and the PTA, but she was also a 'Friend' of the Altadena Public Library, and a founding member of La Cañada Valley Beautiful," she said. "We faithfully attended the Throop Memorial Universalist Church in Pasadena. Many of the members were from Caltech and it was considered rather an intellectual approach to religion. But, I think my Dad's religion was internal, and not dependent on the formality of organized religion. Certainly his sentiments for the stars and solar system and the wonders of science, and how it all works, can only be classified as reverence.⁴⁸

Bill Pickering liked the outdoors and rediscovered an extension of his Havelock boyhood in a love of fishing—especially fly-fishing. He would often take his family on long hikes in the local mountains and on other occasions for longer vacations in the Sierras where he could practice his fly-fishing skills to good effect.

It was a world apart from the deadly work in which he was engaged and could share with no one, not even Muriel. They could not know it then, but all that was about to change.

Endnotes

- 1 Koppes, Clayton R. *JPL and the American Space Program: A History of the Jet Propulsion Laboratory* (New Haven: Yale University Press, 1982).
- 2 Ibid.
- 3 The Committee for Air Corps Research was one of many specialist groups under the National Academy of Science. Both Millikan and von Kármán were members, a fact that, no doubt, had considerable bearing on its support for Arnold's recommendation.
- 4 Koppes, Clayton R. *JPL and the American Space Program*.
- 5 von Kármán T. *Pioneer in Aviation and Pathfinder in Space* (Boston and Toronto: Little, Brown and Company, 1967).
- 6 In the aftermath of this event, von Kármán and others from the group founded a small commercial company to manufacture the Jet Assisted Take-Off (JATO) units in large quantities for military purposes. They named it the Aerojet Engineering Company. The company flourished and eventually became a major U.S. corporation for the manufacturing of rocket engines of all types.
- 7 Koppes, Clayton R. *JPL and the American Space Program*.
- 8 Ibid.
- 9 The successive stages of the program were named for Army ranks to preserve their association with the Army and to connote increasing levels of capability.
- 10 Pickering, William H., with James H. Wilson. "Countdown to Space Exploration: A Memoir of the Jet Propulsion Laboratory, 1944—1958." In: Hall, ed., *History of Rocketry and Astronautics* (Springfield, Virginia: American Astronautical Society History Series, Vol. 7, Part II, October 1972).
- 11 WAC is thought by some to stand for "Without Attitude Control," others believe it stands for "Women's Army Corps," an allusion to the Corporal sister project. Pickering favored the latter.
- 12 Koppes, Clayton R. *JPL and the American Space Program*.
- 13 von Kármán, Theodore. *Pioneer in Aviation and Pathfinder in Space* (Boston and Toronto: Little, Brown and Company, 1967); Gorn, Michael H. *The Universal Man: Theodore von Kármán's Life in Aeronautics* (Washington and London: Smithsonian Institution Press, 1992).
- 14 Wilson, James H. Interviews with William H. Pickering. Pasadena, California: Oral History Program, Jet Propulsion Laboratory, 1972.
- 15 Pickering, William H., with James H. Wilson. "Countdown to Space Exploration: A Memoir of the Jet Propulsion Laboratory, 1944—1958." In: Hall, ed., *History of Rocketry and Astronautics* (Springfield, Virginia: American Astronautical Society History Series, Vol. 7, Part II, October 1972).
- 16 Beth Pickering Mezitt. Personal recollections of my Father, William H. Pickering. Private communication to the author: May, 2003.
- 17 Mudgway, Douglas, J. Oral history interview with William H. Pickering: Part 5. Pasadena, California, May 2003.
- 18 Koppes, Clayton R. *JPL and the American Space Program*.
- 19 Ibid.
- 20 Mudgway, Douglas J. Oral history interview with William H. Pickering: Part 5. Pasadena, California, May 2003.
- 21 Pickering, William H., with James H. Wilson. "Countdown to Space Exploration: A Memoir of the Jet Propulsion Laboratory, 1944-1958." In: Hall, ed., *History of Rocketry and Astronautics* (Springfield, Virginia: American Astronautical Society History Series, Vol. 7, Part II, October 1972).

- 22 Pickering, W. H. "Control and Telemetry for Corporal-E." Pasadena, California: Jet Propulsion Laboratory, Progress Report No. 4-15, May 1945.
- 23 Ibid.
- 24 Pickering, William H., with James H. Wilson. "Countdown to Space Exploration: A Memoir of the Jet Propulsion Laboratory, 1944—1958." In: Hall, ed., *History of Rocketry and Astronautics* (Springfield, Virginia: American Astronautical Society History Series, Vol. 7, Part II, October 1972).
- 25 Ibid.
- 26 Pickering, William H. and Robert J. Parks. "Guidance and Control System." Alexandria, Virginia: United States Patent Office, Number 3,179,353, 20 April 1965. Some time later, according to Pickering, the Army asked JPL to establish patent rights for this idea which, at the time, was being also being used by a contractor for the Army's Nike antiaircraft defense system. By establishing its prior use claim, JPL secured the patent thereby simplifying the Army's negotiations with its Nike contractor since JPL was already a prime contractor for the Army. "Unfortunately," he added, "we never collected any royalties on it."
- 27 Pickering, W. H., and J. A. Young. "External Instrumentation for NAMT." Pasadena, California: Jet Propulsion Laboratory Progress Report No. 10-1 to 10-9, 1946—1947; Pickering, W. H. and P. H. Reedy. "External Instrumentation for NAMTC." Pasadena, California: Jet Propulsion Laboratory, Progress Report No.18-1 to 18-8, 1949—1950.
- 28 Wilson, James H. Interviews with William H. Pickering. Pasadena, California: Oral History Program, Jet Propulsion Laboratory, 1972.
- 29 Mudgway, Douglas J. Oral history interview with William H. Pickering: Part 5. Pasadena, California, May 2003.
- 30 Ibid.
- 31 Ibid.
- 32 Ibid.
- 33 Wilson, James H. Interviews with William H. Pickering. Pasadena, California: Oral History Program, Jet Propulsion Laboratory, 1972.
- 34 Koppes, Clayton R. *JPL and the American Space Program*.
- 35 The drag brakes that Pickering refers to here were the outcome of the automobile "rear doors drag" experiment that the JPL team performed while driving back to the White Sands base from Las Cruces.
- 36 Pickering, William H., with James H. Wilson. "Countdown to Space Exploration: A Memoir of the Jet Propulsion Laboratory, 1944—1958." In: Hall, ed., *History of Rocketry and Astronautics* (Springfield, Virginia: American Astronautical Society History Series, Vol. 7, Part II, October 1972).
- 37 In those days, late-1940s to early 1950s, "upper-atmosphere" was synonymous with "space."
- 38 Pickering, W. H. "Study of the Upper Atmosphere by Means of Rockets." Pasadena, California: Jet Propulsion Laboratory, Publication No. 15, June 1947.
- 39 By international agreement, the IGY would run from 1 July 1957 through 31 December 1958.
- 40 The Redstone, a descendent of the V-2 German missile, was developed at the Army Ballistic Missiles Agency (ABMA) in Huntsville, Alabama.
- 41 Pickering, William H., with James H. Wilson. "Countdown to Space Exploration: A Memoir of the Jet Propulsion Laboratory, 1944—1958." In: Hall, ed., *History of Rocketry and Astronautics* (Springfield, Virginia: American Astronautical Society History Series, Vol. 7, Part II, October 1972).
- 42 See Folder 4 in the William H. Pickering Speech Collection. Pasadena, California: Archives and Records Center, Jet Propulsion Laboratory, JPL-181, 2003.

Chapter 3: The Cold War Warrior

- 43 NRL in Washington, DC, was, in many ways, a counterpart to JPL in that it engaged in research and development tasks for the Navy rather than the Army.
- 44 See Folder 5 in the William H. Pickering Speech Collection. Pasadena, California: Archives and Records Center, Jet Propulsion Laboratory, JPL-181, 2003.
- 45 See Folder 6 in the William H. Pickering Speech Collection. Pasadena, California: Archives and Records Center, Jet Propulsion Laboratory, JPL-181, 2003.
- 46 See Folder 7 in the William H. Pickering Speech Collection. Pasadena, California: Archives and Records Center, Jet Propulsion Laboratory, JPL-181, 2003.
- 47 Mudgway, Douglas J. Oral history interview with William H. Pickering: Part 4. Pasadena, California, May 2003.
- 48 Beth Pickering Mezitt. Personal recollections of my Father, William H. Pickering. Private communication to the author: May, 2003.

